

INPROX sensors

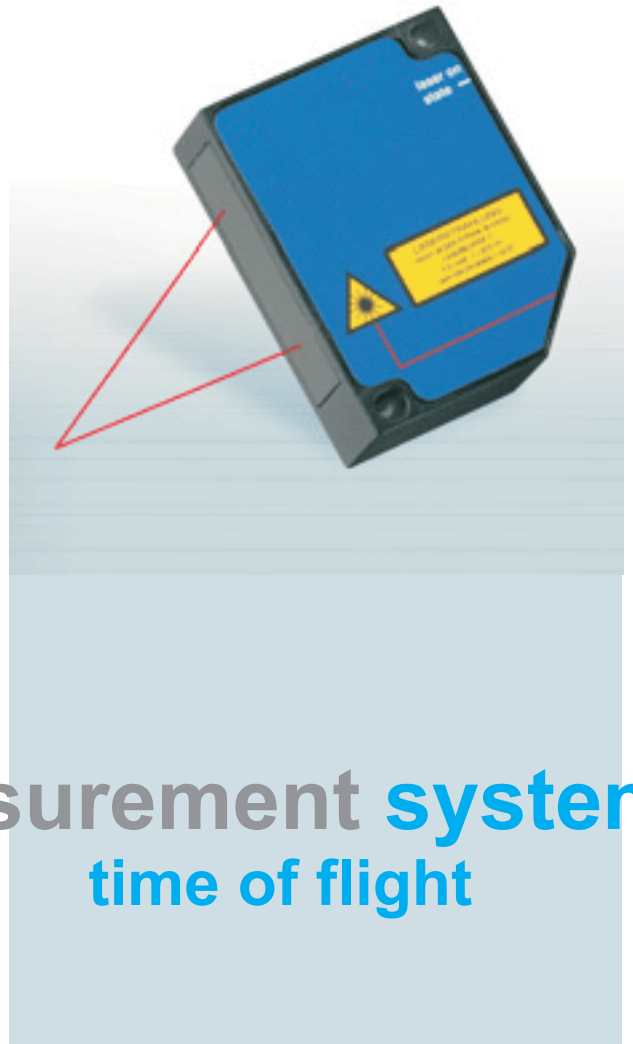
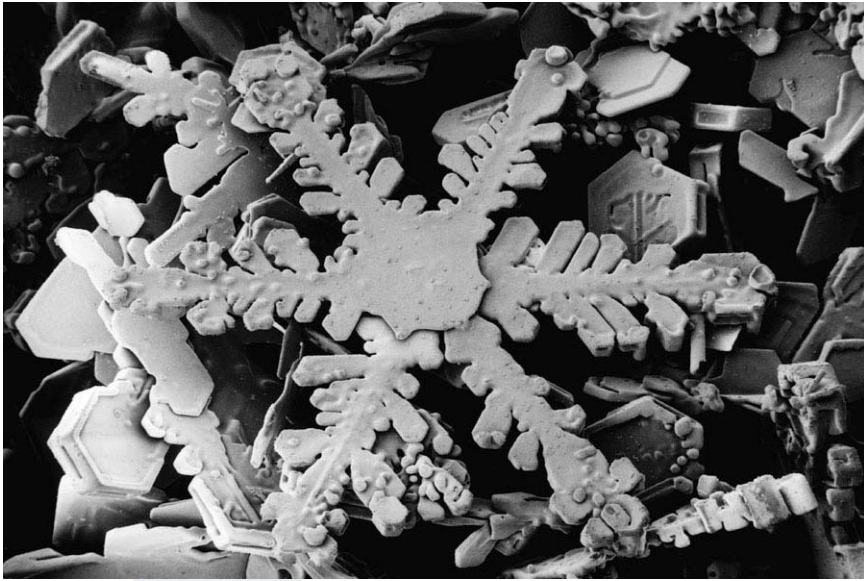

advanced **laser** measurement **system**
time of flight

MLS4

INPROX sensors

advanced laser measurement system

industrial grade distance measurements

With a tough IP67 aluminum housing the MLS4 series of compact time of flight laser sensors is engineered to resist difficult production environments where temperature, dirt and other typical contaminants may impede performance.

«with high shock and vibration resistance

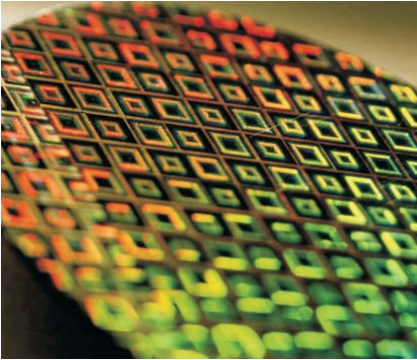

innovative time of flight series

The MLS4 is an innovative laser distance sensor series operating on the principle of time of flight measurement. This technology is based on the measurement of the time between the emission and receipt of laser light pulses.

«laser time of flight



operates independent of color

In the 300-4000mm distance range, it provides a very accurate measurement independent of the targets color with 12 bit resolution and high linearity. This enables the MLS4 series to be extremely stable and allows for highly accurate displacement measurements; regardless of light distribution.

«digital signal processor with intelligent logic

analog and digital outputs

The MLS4 sensors have two switching outputs; available as PNP and NPN models, that can be set at different distances, while the measurement value is supplied through a 4-20mA analog output and RS485 interface. This interface can also be used to set all the parameters. A response time selection with 5ms normal and 1ms fast response is available.

«4-20mA analog output and (2) PNP-NPN switching outputs

2 models in the series

With max ranges from 300-4000mm; and great resolution the MLS4 series offers flexible options for advanced laser time of flight sensors

«300-4000mm range



INPROX sensors

advanced laser displacement system

laser time of flight measurement

- ▣ measuring range 300-4000mm
- ▣ digital resolution 0.9mm
- ▣ switching frequency 100Hz/500 Hz
- ▣ 2x PNP or NPN and 4-20mA-RS485

time of flight advantages

- ▣ wide measuring range
- ▣ high linearity
- ▣ 2 switching points and analog outputs
- ▣ 4 digit digital display integrated with sensor
- ▣ visible laser beam

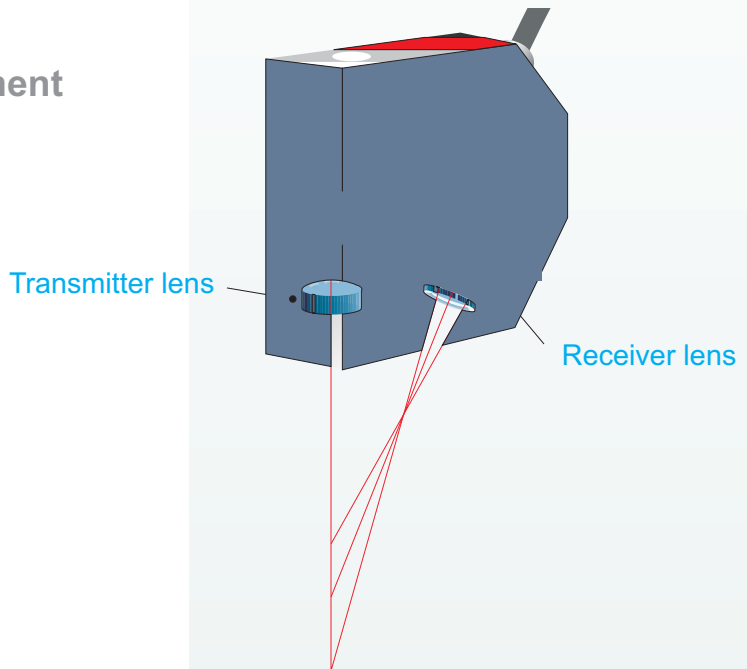

- ¥ highest resolution in class
- ¥ best repeatability in class
- ¥ best cost/performance ratio

integrated 4-digit display

INPROX sensors

advanced laser displacement system

part variation detection for production

The MLS4 can effectively detect height differences in production parts; with tight resolution and color insensitivity.

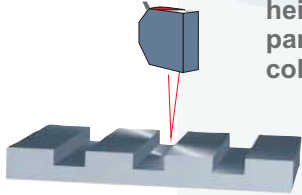

automatic control for coiling/uncoiling machines

On difficult metal product machines the MLS4 performs beyond the spec's in quality applications. Where accurate measurements are critical in production environments; the MLS4 is there.

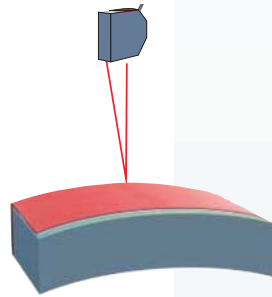
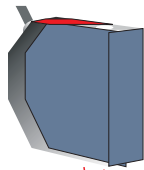

Detecting and measuring solder paste

The MLS4 can effectively detect solder paste in PCB fabrication and other important semi-conductor process control applications.

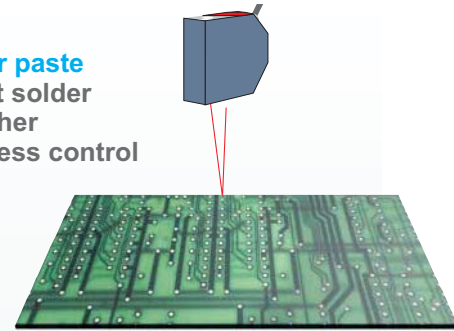

hot steel measurements

The MLS4 with its compact design and small spot diameter rises to the challenge of difficult surface and temperature applications, including distance measurement up to 1200°C hot steel.

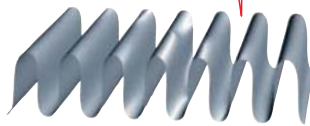

positioning of critical parts in production lines

The MLS4 is a unique measurement tool for process staging; in order to determine the position of the part relative to the tool or robot (punching, presses, drills and sub-assemblies). Trust the MLS4 system for the highly precise measurement of a glossy surface.

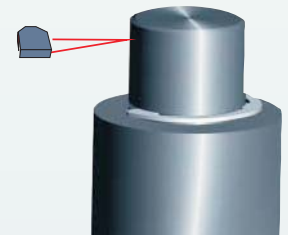

thickness measurement

The thickness of parts and materials can be determined with the MLS4 series laser sensor; using high measuring rates. This series is the ideal choice for moving and in motion targets.

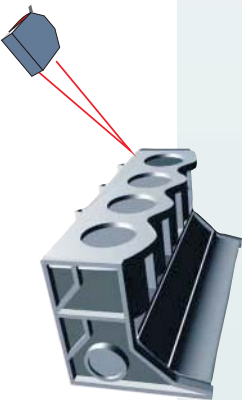

measurement of large objects at long ranges (moving)

The MLS4 is particularly well suited in difficult moving applications involving large objects and long ranges.

MLS4 time of flight sensor is an effective sensor tool in large object staging applications and measurements of critical moving objects including: cranes, cars, and ships.

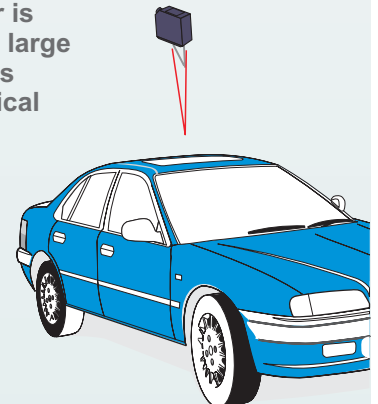

measurement of roll thickness

During paper creation process measuring roll thickness can be a critical application; for the MLS4 series; applications such as this can be effectively solved. This series is the ideal choice for industrial diameter measurements.

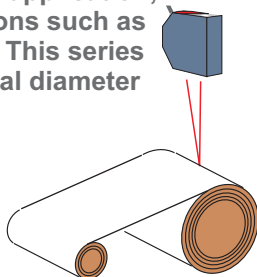

INPROX sensors

advanced laser displacement system

Electrical data	Supply voltage	15 - 30 VDC	
	Ripple	max. 2Vpp	
	Current consumption typ.	max. 170 mA (110 mA at 24V)	
	Data memory	EEPROM	
Specific data	Measuring range (at specified surf. reflection)	300 - 4000 mm (18% grey to 90% white) 400-2500 (at 6% black)	
	Digital resolution (RS485)	³ 0.9 mm	
	Analogue resolution	³ 3 mm	
	Response time	5 ms (normal), 1 ms (fast)	
	Switching frequency	100 Hz (normal), 500 Hz (fast)	
	Linearity	typ. 0.3 % (at 24VDC, at 90% white surface, 25 °C)	
	Outputs	Switching outputs	2x PNP or NPN max. 30 VDC, 100 mA, short circuit protected
		Analogue output	4-20 mA
Input		SYNC-input, PNP	
Serial connection		RS485, 9600 Bd	
Light source	Wave length	665 nm	
	Laser class	2 (EN 60825-1:1994)	
	Measuring spot size typ.	~ Ø 12 mm at 2000 mm distance ~ Ø 20 mm at 4000 mm distance	
Ambient conditions	Operating temperature	-10 to +50 °C	
	Storage temperature	-20 to + 70 °C	
	Protection	IP 67	
	Ambient light protection	according to EN 60947-5-2	
	Vibration	0,5 mm amplitude, 10-55 Hz according to EN 60068-2-6	
	Shock resistance	11 ms (30 G) , acc.to EN60068-2-27	
Housing	Material	Aluminum housing, optical elements: Glass	
	Weight	approx. 330 g	
	Connections	8-pol plug connector, M12, turnable	

Laser Distance Sensor

MLS4LVK8E 4-20mA 2X PNP RS485

MLS4LDK8E 4-20mA 2X NPN RS485

Accessories

Cable 3 m, 8-pin, M12 plug INC12K803A5

Cable 5 m, 8-pin, M12 plug INC12K803A5



LASER CLASS 2
EN 60825-1:1994

**Do not stare
into beam!**

INPROX sensors

28 State Street
Suite 1100
Boston, MA 02109
877 INPROX 7
877 467 7697
617 573 5158
617 507 2665 fax
sales@inproxsensors.com

www.inproxsensors.com

INPROX sensors

advanced laser displacement system

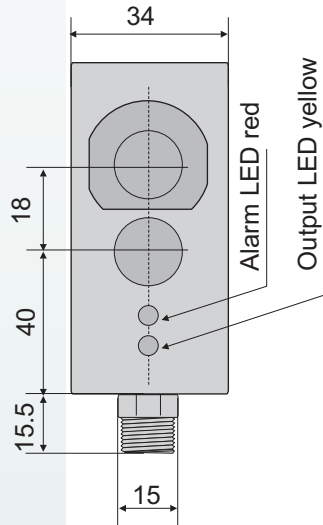

All dimensions in mm

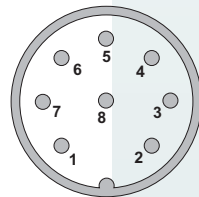
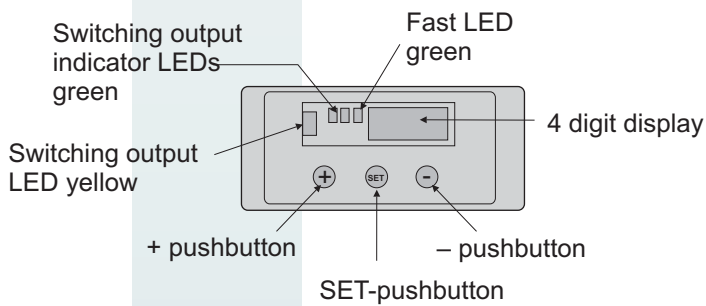
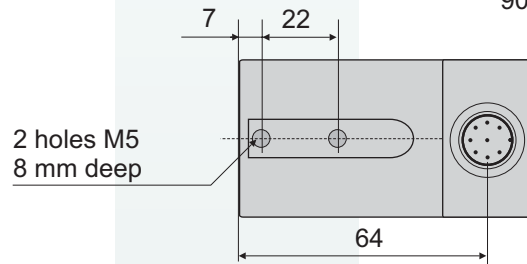
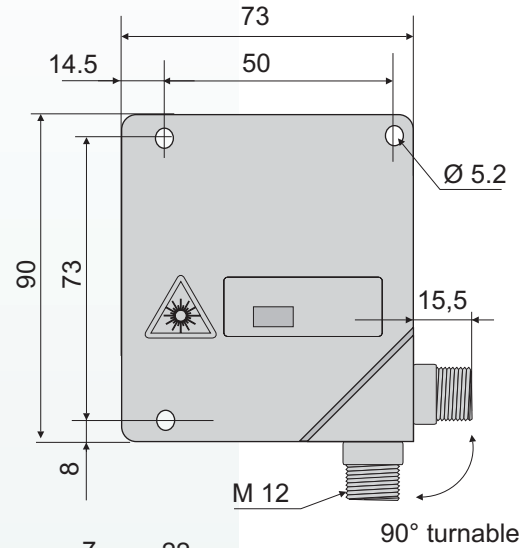

Plug connector M12

- 1 wh Rx/Tx -
- 2 bn +10-30VDC
- 3 gn Analogue output
- 4 ye Output 1
- 5 gr Output 2
- 6 pi Rx/Tx +
- 7 bl GND
- 8 rd SYNC

INPROX sensors

advanced laser displacement system

LED indicators on MLS4 front side

- OUTPUT LED** Yellow LED indicates an active Output (Output 1 OR Output 2)
- ALARM LED** The red ALARM LED indicates a missing receiver signal

Pushbuttons and Display on top

- OUTPUT LED** Yellow LED indicates an active Output (Output 1 OR Output 2)
- Display (green, 4-digit)** In normal working mode, the distance in mm is shown on the display
- LED OUT1, OUT2** Green LED1 indicates the activated switching output 1
Green LED2 indicates the activated switching output 2
- LED FAST** Green LED3 indicates the activated FAST mode (500 Hz)
- SET-pushbutton** A short press on this key activates the self-setting procedure.
A long pressure on the key allows the user to access into the mode (FAST/NORM) and the setting of output delay.
- +/- pushbuttons** Short pressure on this key allows the user to run through parameters and the settings menu of the sensor.
Long pressure allows to change the switching threshold value. (see also "Switching threshold adjustment ")

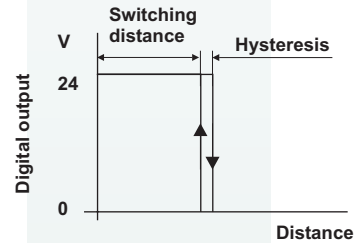
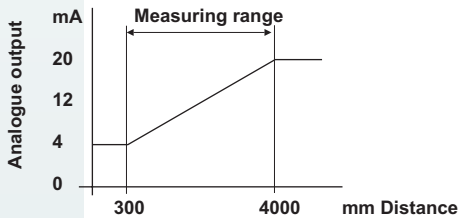
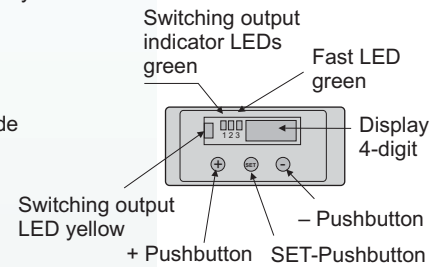
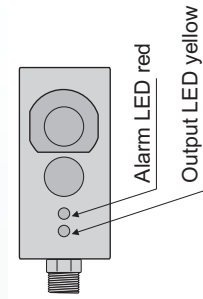

The RS485 serial interface allows the complete remote control of the sensor. All functions as channel status, normal/fast mode selection or output delay can be configured by serial connection. The serial communication parameters are:
9600 baud, non-parity, 8 data bits, 1 stop bit.

The **SYNC**-input is used to determine the communication direction.
SYNC active (LOW) MSL400 -> user
SYNC passive (HIGH) user -> MSL400
With **SYNC** active, the sensor continuously transmits the detected distance value (with a precision of 12 bit) by means of a binary data format. 2 byte are used; one with bit 0 at logic level 1 identifies the high byte.

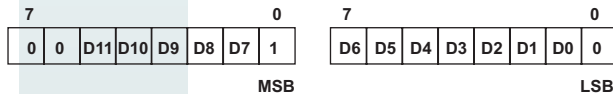

All the commands have to be sent via terminal in ASCII-format according to the following:

- Remote configuration:

To access the remote configuration mode, SYNC-input must be passive. (SYNC passive = HIGH)
The available commands are:

- @ <CR> <LF> beginning of remote setting mode
- cx <CR> <LF> channel selection, with x {1,2}
- vxxx <CR> <LF> distance selection, with xxxx {0-4095}
- bx <CR> <LF> dark/light mode selection, with x {1,2}
b1 = dark-switching
b2 = light-switching
- e <CR> <LF> memorization to the configuration sequence
- q <CR> <LF> exit from remote setting mode without saving

At the receipt of the 'q' <CR> <LF> or 'e' <CR> <LF> -commands, the sensor visualizes ok <CR> <LF>

- Delay configuration:

To access the remote configuration mode, SYNC-input must be passive.

(SYNC passive = HIGH). The available commands are:

- @ <CR> <LF> beginning of delay configuration
- dx <CR> <LF> delay selection with x {0,1,2,3,4,5}
d0 = 0 ms d3 = 20 ms
d1 = 5 ms d4 = 30 ms
d2 = 10 ms d5 = 40 ms
- e <CR> <LF> memorisation of the new delay value
- q <CR> <LF> exit from delay setting mode without saving

At the receipt of the 'q' <CR> <LF> or 'e' <CR> <LF> -commands, the sensor visualises ok <CR> <LF>

- Normal/ fast mode configuration:

To access the remote configuration mode, SYNC-input must be passive. (SYNC passive = HIGH). The available commands are:

- @ <CR> <LF> beginning of remote setting mode
- mx <CR> <LF> operating mode selection with x {1,2}
m1 = normal
m2 = fast
- e <CR> <LF> execution of configuration sequence
- q <CR> <LF> exit from remote setting mode without saving

At the receipt of the 'q' <CR> <LF> or 'e' <CR> <LF> -commands, the sensor visualises ok <CR> <LF>

- Receipt of the channel status:

At any moment, the receipt of the 'r' <CR> <LF> remote command (and SYNC passive), the sensor configuration is restored.

NOTE:

The single digits have to be distanced amongst themselves at least 1 ms, during the command transmission.

INPROX sensors

advanced laser displacement system

Setting of the 2 channels

Detection

Place the object to detect in front of the sensor.
The actual distance value in mm is shown on display.
By pressing the **SET**-button (for at least 2 sec.) you will reach the channel selection.

Channel selection

To select the channels, press the **+/-** - buttons.
You confirm the selection by a short press (0,5 s) of the **SET**- button and will reach the dark/light-selection.

Dark/light-mode

To select the dark/light mode of the channels, use the **+/-** -buttons.
Press the **SET** - pushbutton again for at least 0,5 sec.
On display, the "updt" message starts to blink (4Hz, for 2 s)
The detection distance value appears on display, LED for the memorised channel is active. The **+/-** -pushbuttons can be used to change the detected distance value. (Units change if the pushbuttons pressed repeatedly, the tens if the buttons keep pressed)
Press the **SET**- button again for at least 0.5 s to end the setting of the channels phase.

Display

1945 Distance value

CH-1

CH-2

L On Light switching

d On Dark switching

updt Settings saved

1945 Distance value

Switching threshold adjustment

Channel selection

Press the **+/-** - button for at least 2 sec. the "CH 1"- message appears.
To select the channels, press the **+/-** - buttons.
You confirm the selection by a short press (0,5 s) of the **SET**- button

Distance of threshold phase

The previously detected distance value appears. With a press of the **+/-** -pushbuttons the detected distance value can be changed, (Units change if the pushbuttons pressed repeatedly, the tens if the buttons keep pressed).
Press the **SET**- button again for at least 0.5 s to end the threshold adjustment phase.

1945

CH-1

1945 saved value

1960 new value

MEnu

Setting of the parameter

Press the **SET**-button for at least 6 s to enter into the parameter setting menu.
By pressing the **+/-** -pushbuttons, the user can run up and down within this menu.

Switching frequency

Use the **SET**-pushbutton to select the decided option. Setting of normal or fast mode is equal to both outputs.

Delay setting

The delay value setting is equal to both channels. When a delay value, different from zero, is set, outputs are active for at least the time (in ms) as shown in the display.
Setting: with the **SET** pushbutton you can run through the available delay steps.
You confirm the selection by pressing the **SET**- button again.

nOrM normal, 100 Hz

FAST fast, 500 Hz

d-00 no delay

d-05 5 ms

d-10 10 ms

d-20 20 ms

... 30 ms

d-40 40 ms

CH-1

1945

L On

CH-2

...

SAVE

Quick status display

At each pressure of the **SET**-button, the user can run through the options of the selected channel. By pressing the **SET** -button repeatedly, all options will be visualized sequentially.

Memorisation of the parameter set

Pressing the **SET**-button (the "SAVE"-message blinks for 2 s, 4 Hz) all the changed values are saved and the user exits from the menu and returns to normal mode.
To return to the setting menu, one of the **+/-** -buttons has to be pressed.

After a 10 s inactivity of the pushbuttons, the sensor returns to normal mode visualising the distance.

Keylock (SET pushbutton block)

The keylock function is activated after powering on, if the SYNC terminal is connected to the positive power supply (+VDC) for at least 1 s.
(After the first second, the **SYNC** signal is available for normal operations)
To deactivate the keylock function, the sensor has to be turned off and re-powered while maintaining the **SYNC** wire not connected or ground connected (GND).

SYNC-Input

The **SYNC** signal allows to calculate the beginning and the ending instants of the measurement. Reading cycle begins after the transition of the **SYNC** signal from passive to active and the sensor outputs are updated after max. 400 μ s. All the outputs are deactivated after max. 400 μ s from the active-passive transition. (SYNC passive=Vcc, SYNC active=GND)
The **SYNC** wire is also used to determine the transmission direction when the RS485 serial connection is used.

