

INPROX sensors

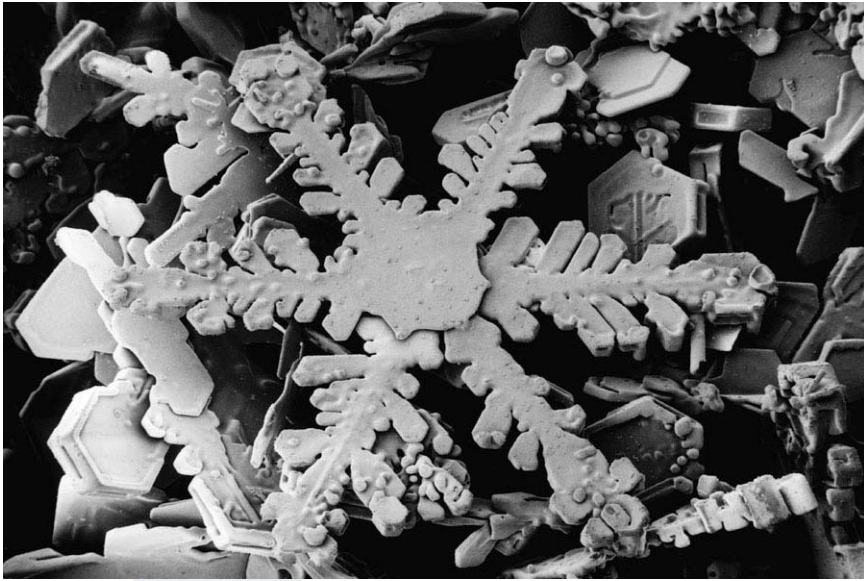

advanced **laser** displacement **system**
compact **CCD** sensor

MLS7

INPROX sensors

advanced laser displacement system

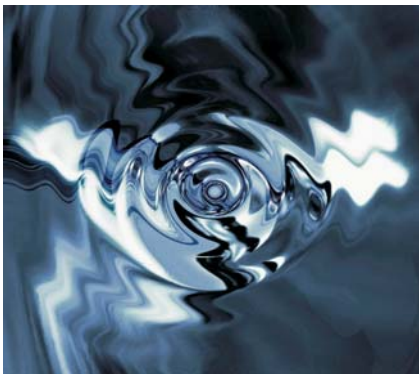
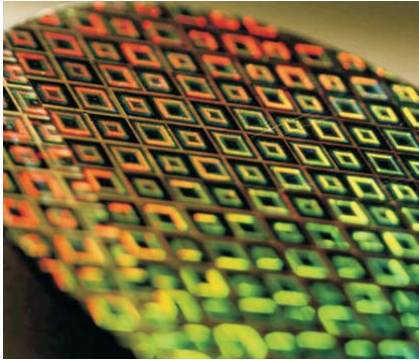

industrial grade distance measurements

With a tough IP67 aluminum housing the MLS7 series of compact laser CCD displacement measurement systems is engineered to resist difficult production environments where temperature, dirt and other typical contaminants may impede performance.

«with 15 G shock and vibration resistance

insensitivity to color changes

The MLS7 series employs CCD technology which virtually eliminates light quantity distribution issues (color variation); by measuring the peak value of light quantity distribution off the beam spot thus detecting individual pixels and identifying this as the critical target position. This enables the MLS7 series to be extremely stable and allows for highly accurate displacement measurements; regardless of light distribution.

«digital signal processor with intelligent logic

analog or digital outputs

Advanced resolution measurements are processed digitally within an integrated controller. Then the analog or digital data obtained can easily be transmitted via RS232/USB connections.

«4-20mA analog output (1-5vdc optional with cable shunt)

multiple control suite

Synchronization, limit systems, averaging and adjustable measurement rates through a user friendly software platform. Integrated Texture-Mapping-Compensation (TMC) allows for variations in surface conditions.

«texture-mapping-compensation

6 models in the series

With max ranges from 5-200mm; and resolution rates from 6 μ m-40 μ m the MLS7 series offers flexible options for advanced laser CCD displacement measurements.

«resolution down to 6 μ m

INPROX sensors

advanced laser displacement system

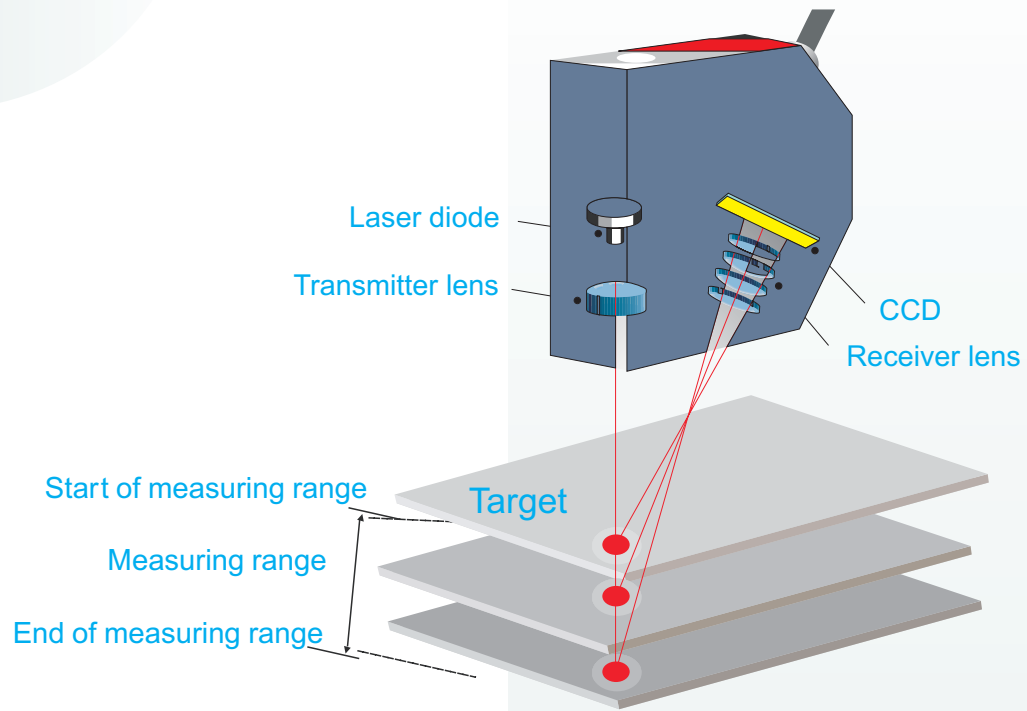

CCD Advantages

- ▣ TMC texture-mapping-compensation for continuity on variable surfaces
- ▣ CCD in a miniaturized housing size
- ▣ PC software control and programmability
- ▣ ability to synchronize (2) or more sensors for thickness and displacement measurements
- ▣ analog and digital outputs



- ¥ highest resolution in class
- ¥ best repeatability in class
- ¥ best cost/performance ratio

pc software included

INPROX sensors

advanced laser displacement system

Part variation detection for production

The MLS7 can effectively detect height differences in production parts; with resolution down to 6µm.

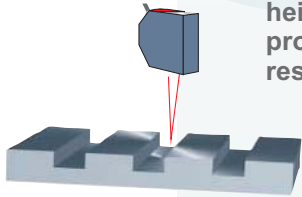

Parts measurements

On difficult metal product surfaces the MLS7 performs beyond the spec's in quality applications. Bending deflection, concentricity, eccentricity and roundness can be accurately measured.

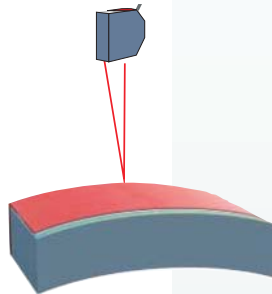
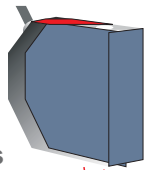

Profiling surface conditions

The MLS7 with its compact design, small spot diameter and texture-mapping-compensation technology rises to the challenge of difficult surface applications involving variations in color, shape, angle and reflectivity.

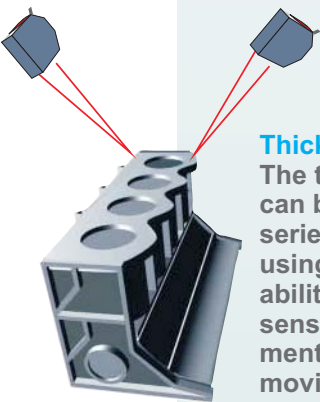
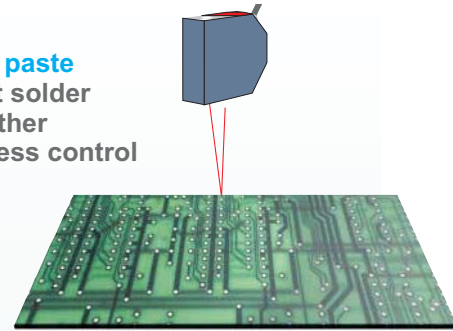

Thickness measurement (synchronous)

The thickness of parts and materials can be determined with the MLS7 series laser displacement system; using high measuring rates and the ability to sequence two or more sensors for simultaneous measurement. This series is the ideal choice for moving and in motion targets.

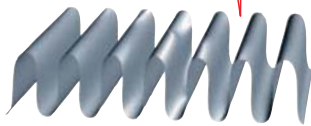

Positioning of critical parts in production lines

The MLS7 is a unique measurement tool for process staging; in order to determine the position of the part relative to the tool or robot (punching, presses, drills and sub-assemblies). Trust the MLS7 system for the highly precise measurement of a glossy surface with the assistance of texture-mapping-compensation technology.



Measurement of pin thickness

During PCB assembly all IC pins must lie in one plane and with the small spot diameter of the MLS7 series; applications such as this can be effectively solved. This series is the ideal choice for moving and in motion targets.

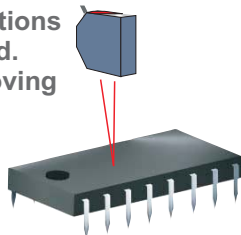

Measurement of "car to road" or "train to road"

The MLS7 is particularly well suited in difficult road and track tests involving the measurement of pitch, roll and brake spring compression. The MLS7 CCD laser displacement sensor system's compact design and the option of running the sensor directly off the vehicle's own power supply. For increased vibration resistance look to our MLS7-250.

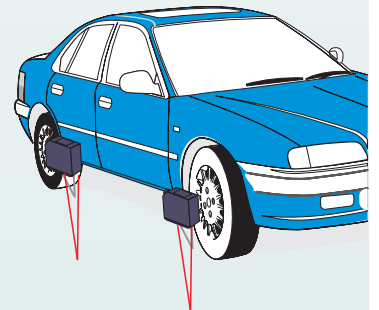

INPROX sensors

advanced laser displacement system

Electrical data	Supply voltage	12-30 VDC, typ. 24 VDC, 150 mA
	Frequency	1 kHz
	Analogue output	4-20 mA (option: 1-5 VDC / 2-10 VDC with shunt)
Light source	Wavelength	typ. 670 nm, visible/red
	Power	< 1 mW
	Laser Class	2 DIN (EN 60825-1:03.97)
Data on ambient conditions	max. operating temp.	0 to +55 °C
	max. storage temp.	-20 to + 70 °C
	Protection	IP 67
	EMV	EN 50081-1 , EN 50082-2

Specific data	Sensor MLS7					
	5	10	20	50	100	200
Measuring range	5 mm	10 mm	20 mm	50 mm	100 mm	200 mm
Center distance	22.5 mm	25 mm	40 mm	70 mm	100 mm	160 mm
Linearity typ.	+/- 5 µm	+/- 10 µm	+/- 20 µm	+/- 50 µm	+/- 100 µm	+/- 400 µm
Resolution stat.(typ.)	0.6 µm	1 µm	2 µm	5 µm	20 µm	40 µm
dyn. at 1 kHz	3 µm	5 µm	10 µm	25 µm	100 µm	200 µm
Meas. area Ø typ.	~0.5 mm	~0.8 mm	~0.4 mm	~0.1 mm	~0.2 mm	~2 mm
Temp. stability	0.03 % of measuring range / °C			0.08 % o.m.r. / °C		

All values at white, diffuse reflective surfaces (AL₂O₃- ceramic) as reference

Distance sensor *

MLS7 Parts Numbers	5	10	20	50	100	200
MLS7	005LXB2E	010LXB2E	020LXB2E	050LXB2E	100LXB2E	200LXB2E

* plug connector included

Cable length:3 m, plug M12, 5-pin 4-20mA INC12B203XA5

Cable length:3 m, plug M12, 5-pin 1-5VDC INC12B203QA5

Cable length:6 m, plug M12, 5-pin 4-20mA INC12B206XA5

INPROX sensors

28 State Street
Suite 1100
Boston, MA 02109
877 INPROX 7
877 467 7697
617 573 5158
617 507 2665 fax
sales@inproxsensors.com

www.inproxsensors.com

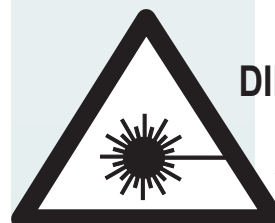

LASER CLASS 2
DIN EN 60825-1: 03.97

Laser radiation
Avoid exposure to beam

Sensors of CLASS 2 does not need environment special protection

INPROX sensors

advanced laser displacement system

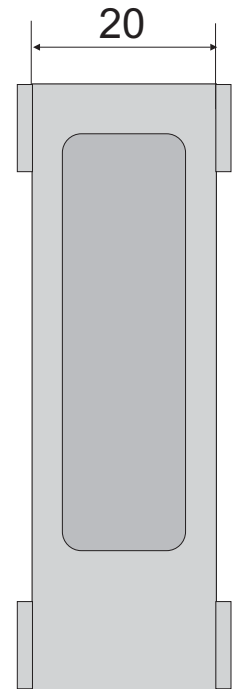
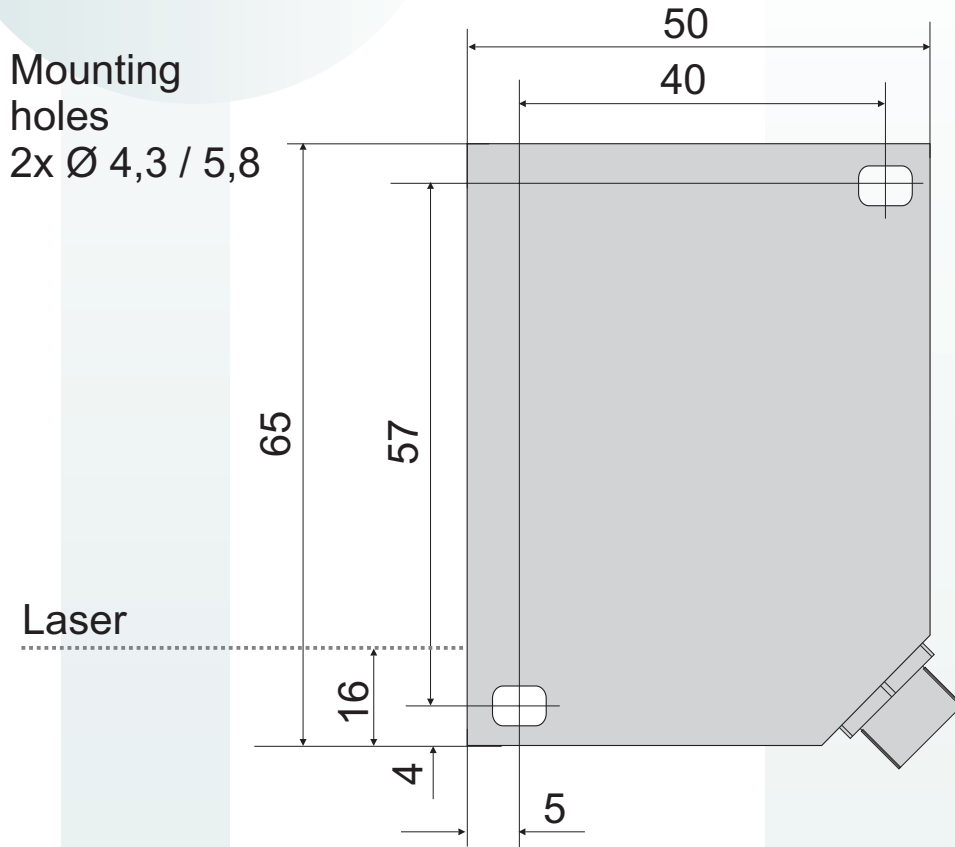

All dimensions in mm

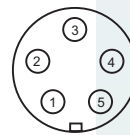

5 pin plug
rear sight

Pin	Color	Reference
1	gn	Error output, open collector NPN; switching to GND, U _{ce} max. 30 VDC, 100 mA, short circuit protected
2	ge	Laser ON/OFF
3	gr	connect pin 2+ 4 => Laser ON
4	bn	Output 4-20 mA, short circuit protected
5	ws	GND
---		Potential for (2) and U _b (5)
		Supply 12-30 VDC
		inverse polarity protected
		Shield (PE)