

INPROX sensors

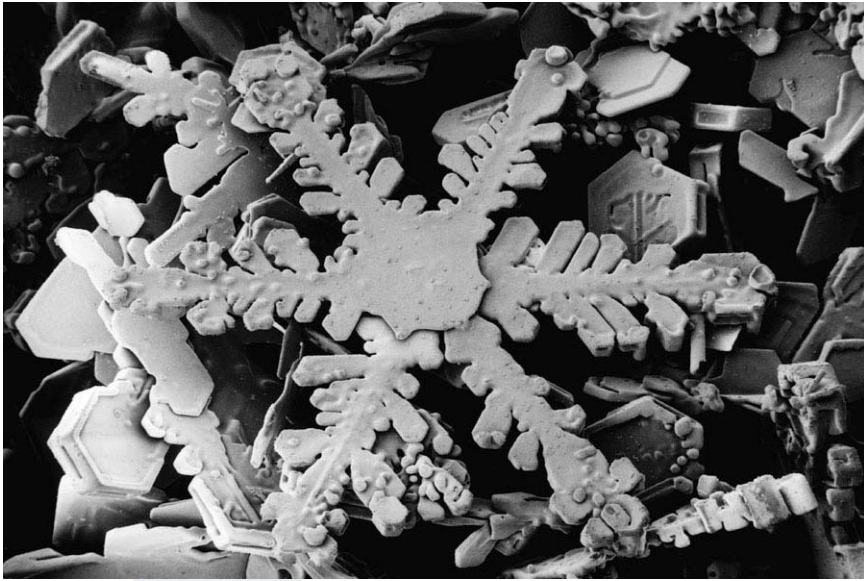

advanced **laser** displacement **system**
compact **ccd-laser** distance **sensor**

MLS7-250

high **vibration** and **shock** resistant **system**

INPROX sensors

advanced laser displacement system

laser-CCD specifications

- ▣ measuring range 250mm
- ▣ resolution >50µm
- ▣ measuring frequency 1000Hz
- ▣ small dimensions (mm) (65x50x20)
- ▣ high shock resistance ~20g

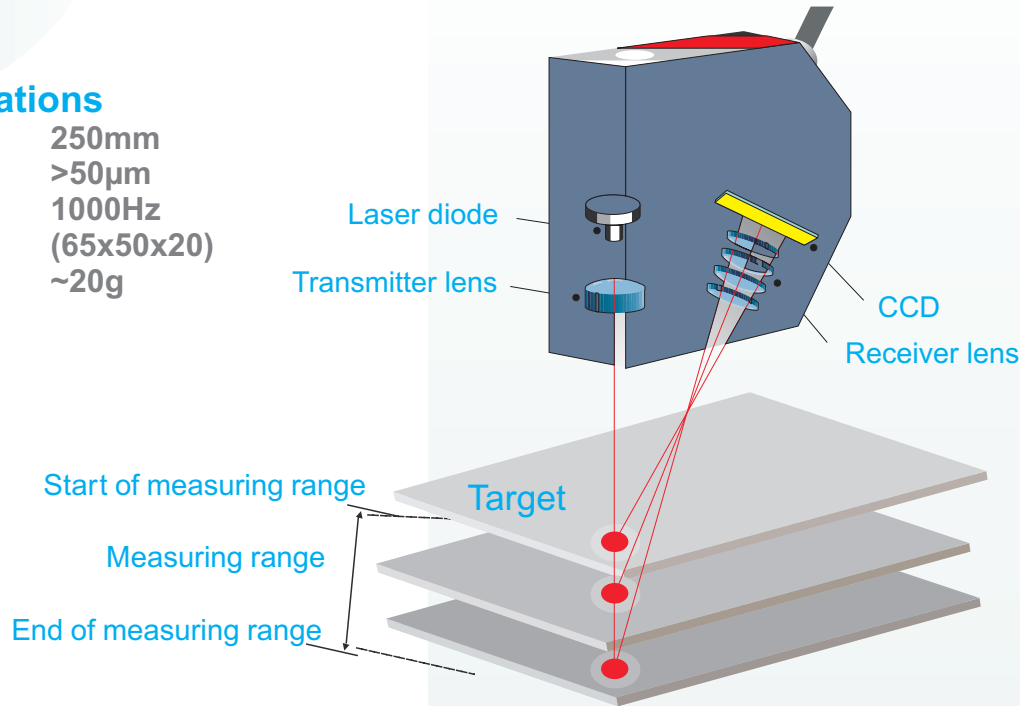

CCD advantages

- ▣ CCD in a miniaturized housing size
- ▣ PC software control and programmability
- ▣ ability to synchronize (2) or more sensors for thickness and displacement measurements
- ▣ analog and digital outputs



- ¥ highest resolution in class
- ¥ best repeatability in class
- ¥ best cost/performance ratio
- ¥ highest shock rating in ccd systems 20G

pc software included

INPROX sensors

advanced laser displacement system

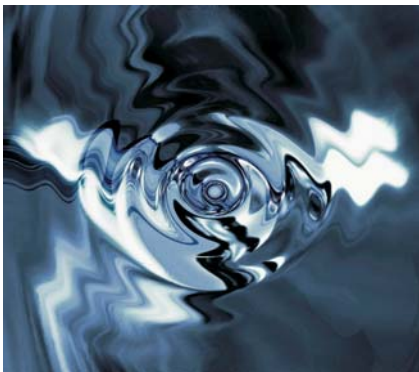
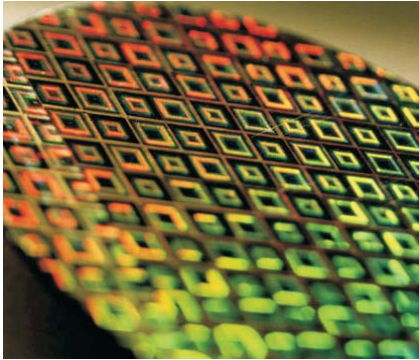

industrial grade distance measurements

With a tough IP67 aluminum housing the MLS7-250 series of compact laser CCD displacement measurement systems is specially engineered to resist difficult production and outdoor environments where temperature, dirt, vibration and shock issues may impede performance.

«with ~20 G shock and vibration resistance

insensitivity to color changes

The MLS7-250 employs CCD technology which virtually eliminates light quantity distribution issues (color variation); by measuring the peak value of light quantity distribution off the beam spot thus detecting individual pixels and identifying this as the critical target position. This enables the MLS7-250 to be extremely stable and allows for highly accurate displacement measurements; regardless of light distribution.

«digital signal processor with intelligent logic

analog or digital outputs

Advanced resolution measurements are processed digitally within an integrated controller. Thus analog or digital data obtained can easily be transmitted via RS232/USB connections.

«4-20mA analog output (1-5vdc optional with cable shunt)

multiple control suite

Synchronization, limit systems, averaging and adjustable measurement rates through a user friendly software platform.

«texture-mapping-compensation

••• **Special application ability is the measurement of the distance from a car body or from a train body to the rail**

INPROX sensors

advanced laser displacement system

Part variation detection for production

The MLS7-250 can effectively detect height differences in production parts; with resolution down to 50µm.

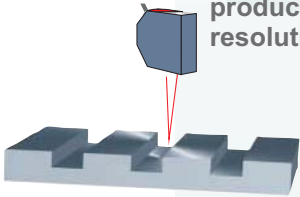

Parts measurements

On difficult metal product surfaces the MLS7-250 performs beyond the spec's in quality applications. Bending deflection, concentricity, eccentricity and roundness can be accurately measured.

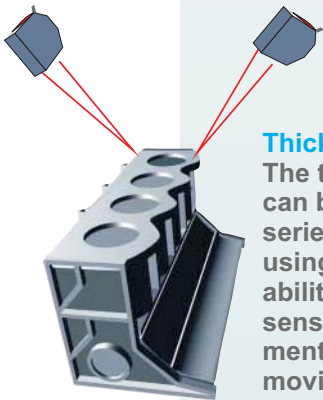
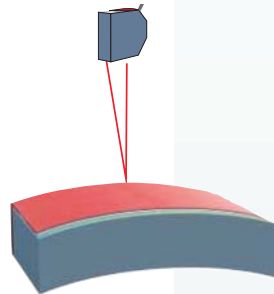
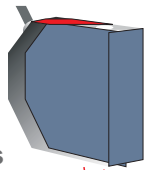

Thickness measurement (synchronous)

The thickness of parts and materials can be determined with the MLS7-250 series laser displacement system; using high measuring rates and the ability to sequence two or more sensors for simultaneous measurement. This series is the ideal choice for moving and in motion targets.

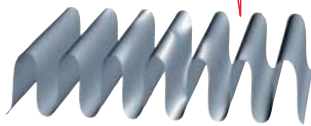

Measurement of pin thickness

During PCB assembly all IC pins must lie in one plane and with the small spot diameter of the MLS7-250 series; applications such as this can be effectively solved. This series is the ideal choice for moving and in motion targets.

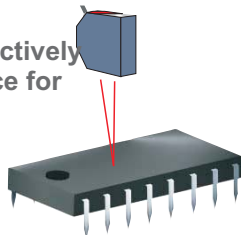

road measurement

The MLS7-250 can effectively measure the distance from the body of a vehicle to the road regardless of surface color.

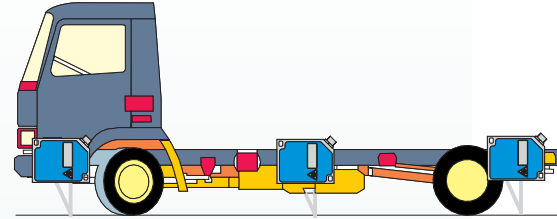

Profiling surface conditions

The MLS7-250 with its compact design, small spot diameter and texture-mapping-compensation technology rises to the challenge of difficult surface applications involving variations in color, shape, angle and reflectivity.

Positioning of critical parts in production lines

The MLS7-250 is a unique measurement tool for process staging; in order to determine the position of the part relative to the tool or robot (punching, presses, drills and sub-assemblies). Trust the MLS7-250 system for the highly precise measurement of a glossy surface with the assistance of texture-mapping-compensation technology.



Measurement of "car to road" or "train to road"

The MLS7-250 is particularly well suited in difficult road and track tests involving the measurement of pitch, roll and brake spring compression. The MLS7-250 CCD laser displacement sensor system's compact design and the option of running the sensor directly off the vehicle's own power supply; especially effective in high vibration environments.

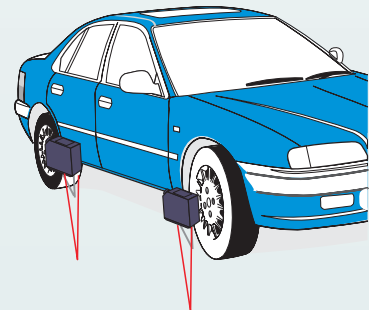

INPROX sensors

advanced laser displacement system

Electrical data	Supply voltage	11-30 VDC, typ. 24 VDC, 150 mA
	Frequency	1000 Hz
	Analogue output	4-20 mA (option: 1-5 VDC/ 2-10 VDC with shunt)
Light source	Wavelength	typ. 670 nm, visible/red
	Power	< 1 mW (IEC standard)
	Laser Class	2 DIN (EN 60825-1:03.97)
Data on ambient conditions	max. operating temp.	0 to +55 °C
	max. storage temp.	-20 to +70 °C
	Protection	IP 67
	max. permis. daylight	<7000 Lux diffuse reflection of sunlight
	EMV	EN 50081-1 , EN 50082-2
Measuring	Measuring range	250 mm
	Center distance	225 mm +/- 125 mm
	Linearity typ.	+/- 0.5 % +/- 0.6 mm
Resolution	stat. (typ.)	~ 50 µm
	dyn. at 1kHz (typ.)	~300 µm
Measuring area	typ.	0.15 - 8 mm Ø start range- end range
	at center dist. (typ.)	~ 4 mm Ø
Temperature	Temperature stability	0.08 % of measuring range / °C

All values at white, diffuse reflective surfaces (AL₂O₃- ceramic) as reference

Distance sensor MLS7250

Cable length 3 m, 5-pin, output 4-20 mA
Cable length 3 m, 5-pin, output 1-5 VDC
Cable length 6 m, 5-pin, output 4-20 mA

Part No.

MLS7250LXB2E
INC12B203XA5
INC12B203QA5
INC12B206XA5

INPROX sensors

28 State Street
Suite 1100
Boston, MA 02109
877 INPROX 7
877 467 7697
617 573 5158
617 507 2665 fax
sales@inproxsensors.com

www.inproxsensors.com

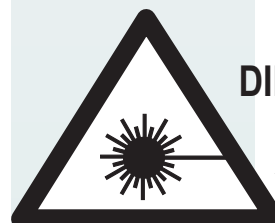

LASER CLASS 2
DIN EN 60825-1: 03.97

Laser radiation
Avoid exposure to beam

Sensors of CLASS 2 does not need environment special protection

INPROX sensors

advanced laser displacement system

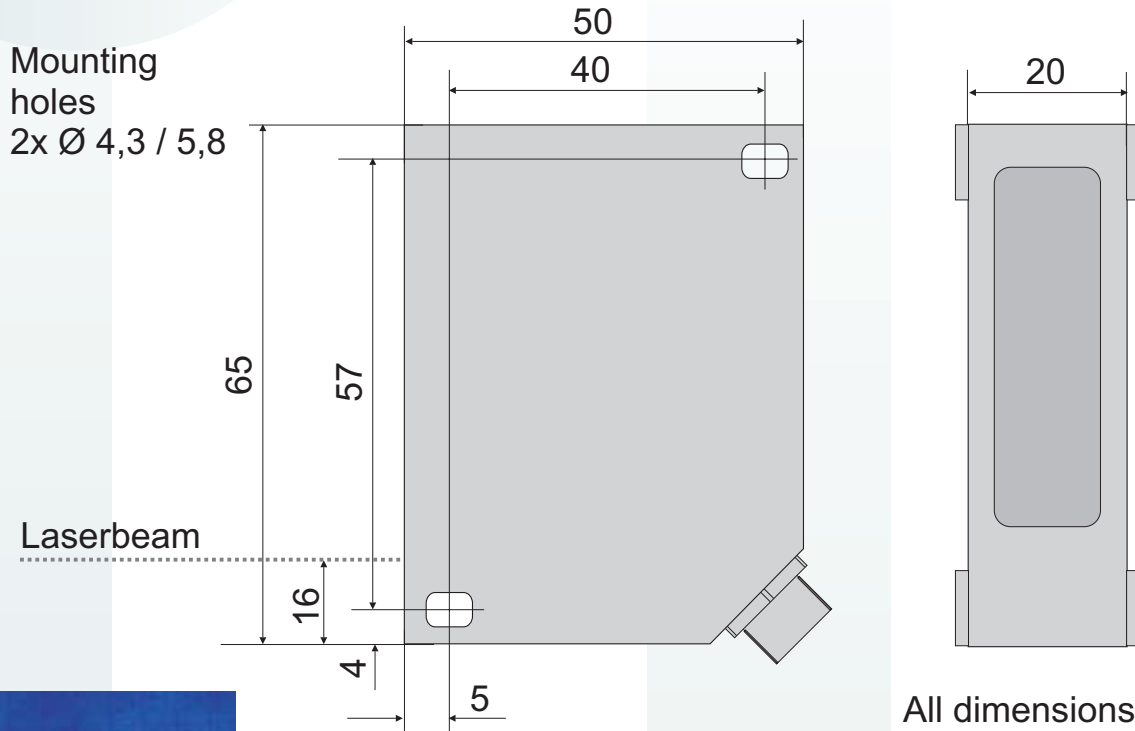

All dimensions in mm



Pin	Colour	Reference
1	gn	Error output, open collector NPN; switching to GND, U _{ce} max. 30 VDC, 100 mA, short circuit protected
2	ge	Laser ON/OFF
3	gr	Output 4-20 mA, short circuit protected
4	bn	GND
5	ws	Potential for (2) and U _b (5) Supply 11-30 VDC inverse polarity protected
---		Shield (PE)

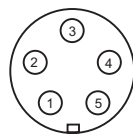

5 pin plug rear sight