

# **INPROX** sensors

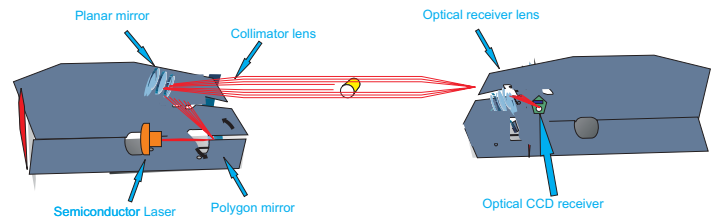

**laser-CCD camera micrometer**

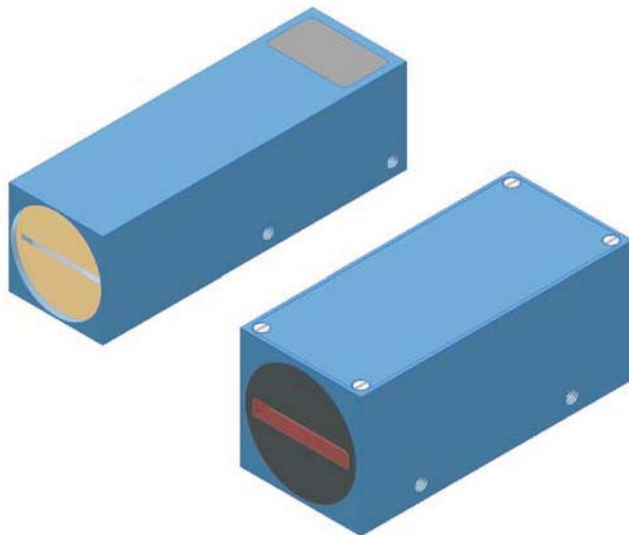

**MMS25A**

# **INPROX** sensors

advanced **laser** measurement **system**

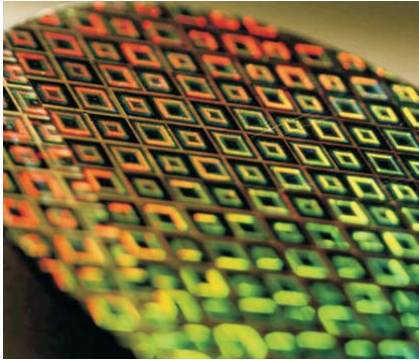

## **advanced laser-CCD camera micrometer**

Engineered to be used in the production and quality assurance of non-contacting and highly dynamic measurements on running conveyors, extrusion lines, drawing processes, on machines and in automated production.

«**diameter, gap, edge, thickness, out-of balance**

## **MMS25A sensor series**

The MMS25A is a laser based measurement system with an integrity high resolution CCD camera for the measurement of dimension. The high sampling rate, outstanding accuracy and excellent resolution for the non-contact measurement and inspection of moving products in the production line.

«**resolution to 25µm (0.00098 inches)**



## **shadow principle**

The MMS25A measures the dimensions of a target or the position of an edge by using the shadow principle. The data obtained with a selection of various measurement programs is output via analog and digital interfaces.

«**programs and interfaces**

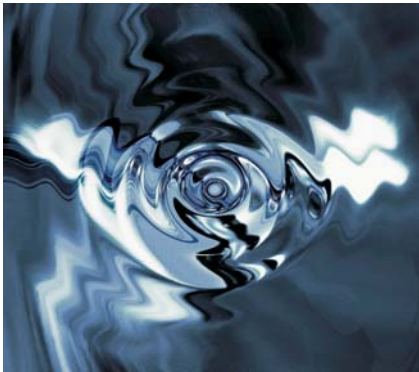

## **sensor system**

The MMS25A consists of a sensor unit and software package. A parallel light curtain is produced using a laser light source. The CCD camera in the receiver section measures with high accuracy the target contour formed by the shadow. The sensor unit is controlled and evaluated by an intelligent TB Scope package with graphical display for the operation and measurement function.

«**intelligent software**

# INPROX sensors

advanced laser displacement system

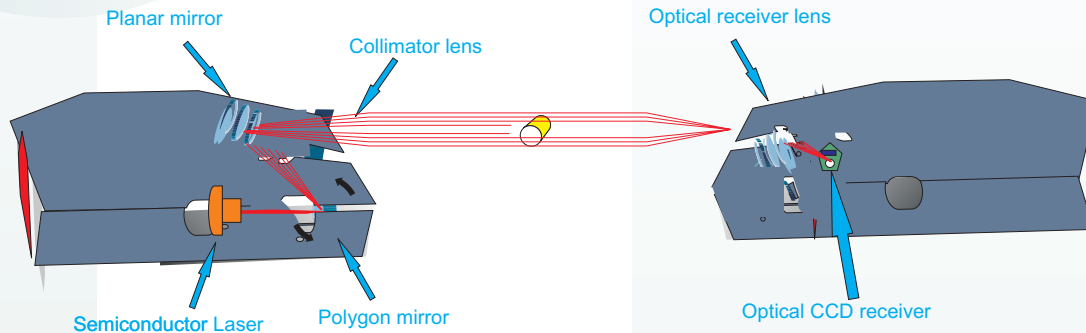

- ¥ highest dissolution in class
- ¥ highest accuracy & linearity in class
- ¥ display on controller screen

## applications

- ❑ extruding lines
- ❑ thickness measurement
- ❑ displacement measuring & profile checking
- ❑ segment measurements
- ❑ measurements of glass+plastics
- ❑ out of balance measurement
- ❑ edge control & position control

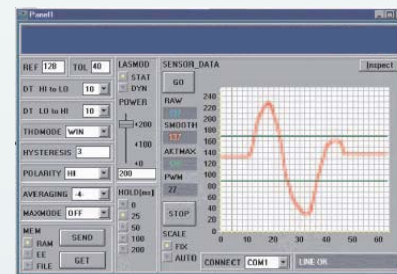
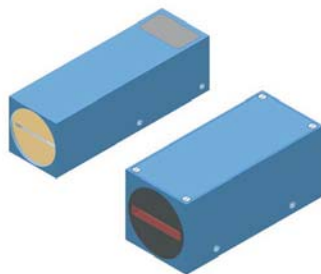

## MMS25A features

- ❑ resolution to 25µm
- ❑ 1 analog output
- ❑ 2 digital outputs
- ❑ ccd line detector with 1024 pixels
- ❑ RS323 and Windows® user interface
- ❑ polarization filter

## TB Scope Software Package

# INPROX sensors

advanced laser displacement system

## edge control

The MMS25A can effectively measure and control width and sheet edge applications.

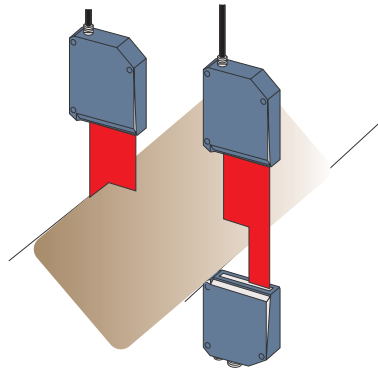

## surface measurements

The MMS25A can effectively detect accurately the surface vibrations and surface conditions of materials such as optical disks

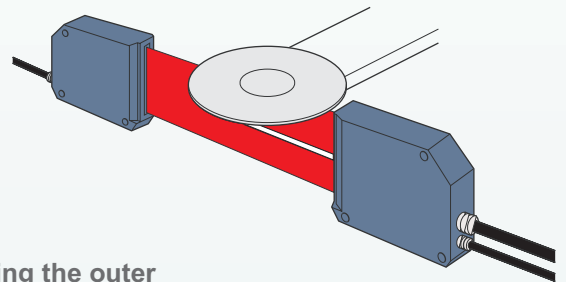

## x-y

The MMS25A is a unique tool in measuring the outer diameter of the critical objects in the X and Y directions.

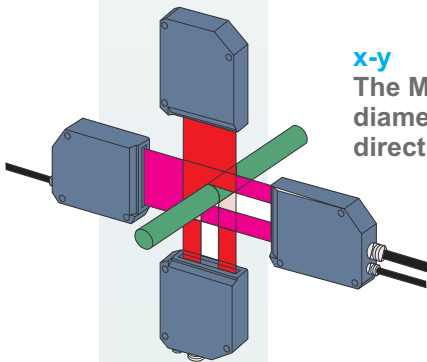

## outer diameter

Again, the MMS25A is an important tool in measuring the outer diameter of the mouth of a transparent bottle.

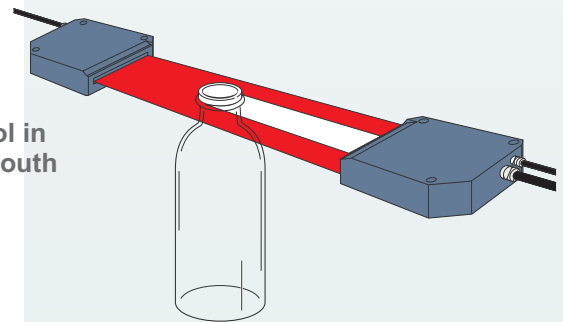

## outer diameter 2

Utilizing 2 MMS25A sensors we are able to obtain accurate measurements of the outer diameter of a large roller shaft.

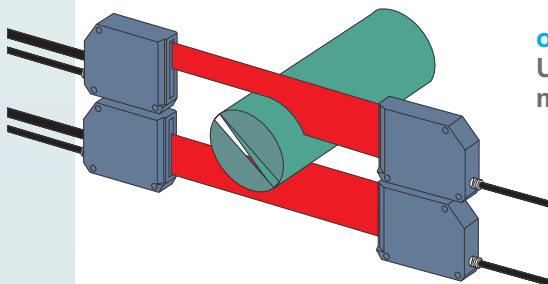

Model	MMS25AE	
Laser	Semiconductor laser, 670 nm, DC-operation, 1 mW max. opt. power, laser class 2 acc. to DIN EN 60825. The use of these laser sensors therefore requires no additional protective measures.	
Optical filter	Interference filter, red light filter RG630, polarisation filter	
Analog output	0 ... +10V	
Digital output (OUT0, OUT1)	pnp bright-switching (pnp n.c.)/npn dark-switching (npn n.o.) or pnp dark-switching (pnp n.o.)/npn bright-switching (npn n.c.), adjustable under Windows®, 100 mA, short-circuit-proof	
Digital input (IN0)	Input voltage +Ub/0V, with protective circuit	
Voltage supply	+12VDC ... +30VDC	
Sensitivity setting	under Windows® via PC	
Laser power correction	Dynamic/static mode adjustable under Windows® via PC	
Current consumption	typ. 200 mA	
Enclosure rating	Electronics: IP54, optics: IP67	
Operating temperature range	-20°C ... +50°C	
Storage temperature range	-20°C ... +85°C	
Housing material	Aluminum, anodized in blue	
Housing dimensions	Transmitter: LxWxH approx. 10 mm x 34 mm x 34 mm (without connector) Receiver: LxWxH approx. 90 mm x 40 mm x 40 mm (without connectors)	
Type of connectors of receiver	8-pin female connector type Binder Series 712 (PLC/Power) 4-pin M5 female connector Typ Binder Series 707 (PC/RS232) 3-pin female connector Binder Series 712 (connection to the transmitter)	
Type of connector of transmitter	3-pin female connector Binder Series 712 (connection to the receiver)	
Teach button	Teach button at the housing for set point value teaching	
LED indication	LED red (+) : Measured value > upper tolerance threshold LED green : Voltage indication/visualisation of teach process LED red (-) : Measured value < lower tolerance threshold	
EMC test acc. to	IEC -801 ...	
Scan frequency	max. 100 Hz	
Max. switching current	100 mA, short-circuit-proof	
Interface	RS232, parameterisable under Windows®	
Connecting cables	Connection to PC: cab-las4/PC or cab-las4/PC-w (max. length 15 m) Connection to PLC: cab-las8/SPS or cab-las8/SPS-w (max. length 25 m) Connection of transmitter and receiver: cab-las3-male (max. length 15 m)	
Output polarity	Bright-/dark-switching,	adjustable under Windows®
Measuring range	typ. 25 mm	
Resolution	typ. 25 µm	

# INPROX sensors

advanced laser displacement system

## Connector Assignment

### Connection for TB Scope and PLC 8-pol. Socket Binder Series 712

Pin No.:	(Color)	Assignment:
1	(wht)	GND (0V)
2	(brn)	+24VDC
3	(grn)	IN0
4	(yel)	IN1 (n.c.)
5	(gry)	OUT0
6	(pnk)	OUT1
7	(blu)	GND (0V)
8	(red)	ANA (0-10V)

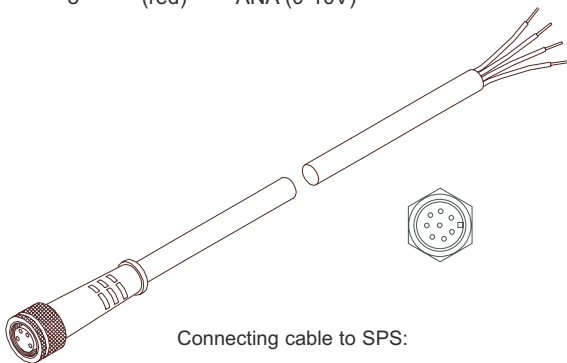

### Connection for TB Scope and PC: 4-pole connector Binder 707

Pin:	Assignment:
1	GND (0V)
2	GND (0V)
3	RX0
4	TX0.

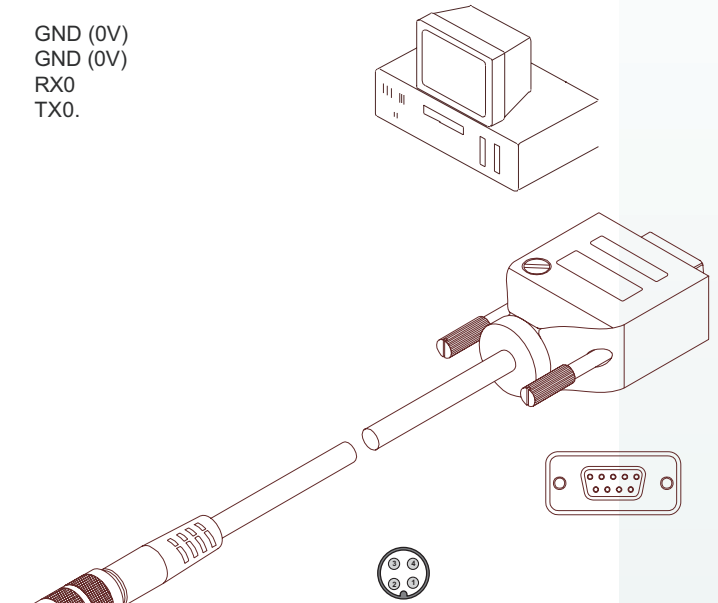

### Connection for sender and receiver optics: 3-pole connector Binder 712

Pin:	Assignment:
1	+5VDC
2	GND (0V)
3	I-CONTROL (0V-+5V)

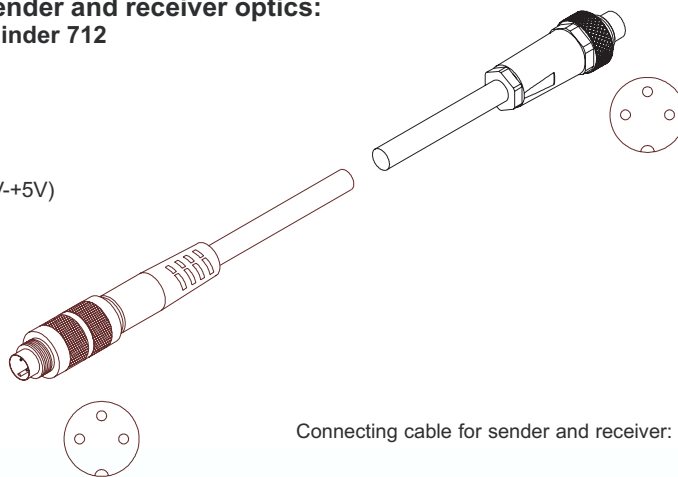

## Laser Warning

The laser reflex sensors of MMS Series comply with laser class II according to EN 60825. The use of these laser sensors therefore requires no additional protective measure.

The laser reflex sensors of MMS Series are supplied with a laser warning label.

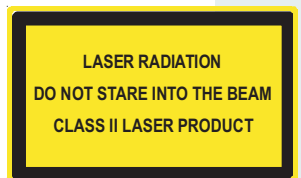

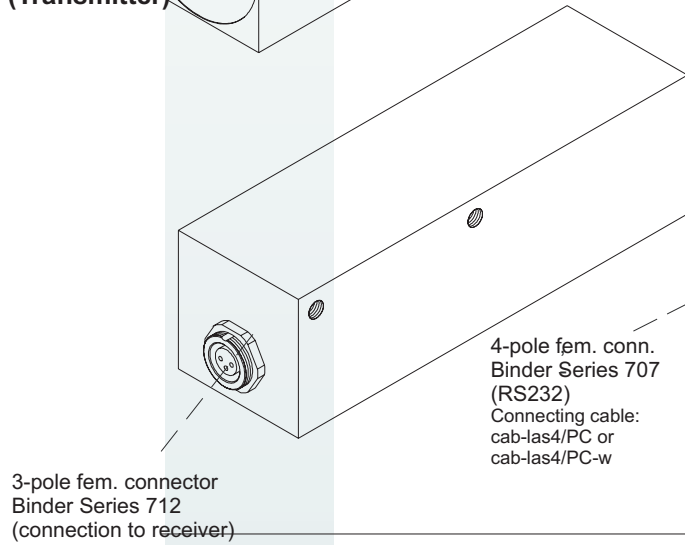
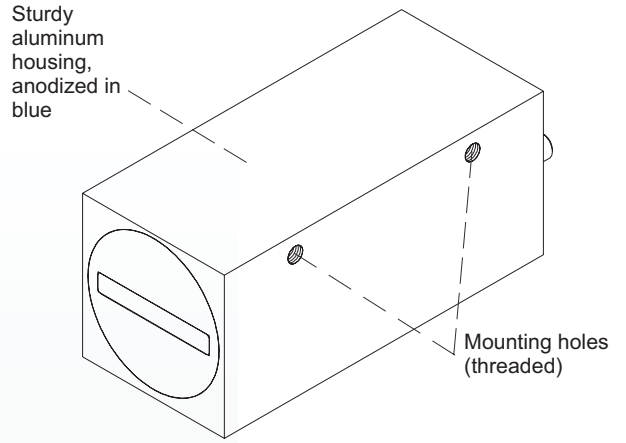
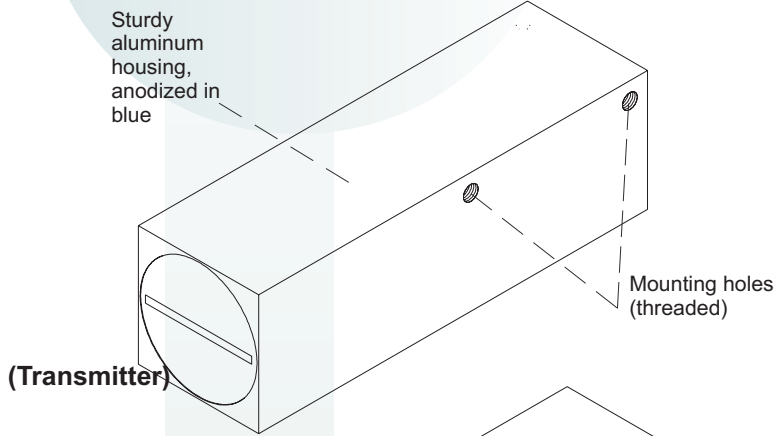

8-pole fem. conn. Binder Series 712 (PLC)  
Connecting cable: cab-las8/SPS or cab-las8/SPS-w

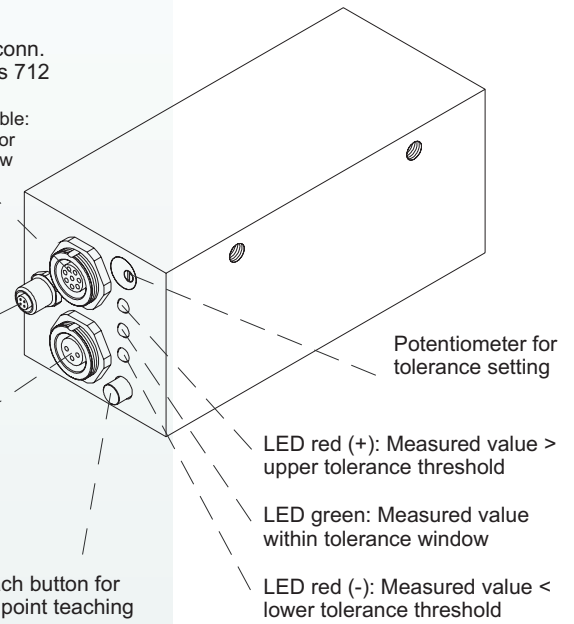

4-pole fem. conn. Binder Series 707 (RS232)  
Connecting cable: cab-las4/PC or cab-las4/PC-w

3-pole fem. connector Binder Series 712 (connection to transmitter)  
Connecting cable: cab-las3-male

### Included components

sensor unit (laser light source + receiver), software, head connector, all connectors



**LASER CLASS 2**  
**EN 60825-1:1994**  
**Do not stare into beam!**

### INPROX sensors

28 State Street  
Suite 1100  
Boston, MA 02109  
877 INPROX 7  
877 467 7697  
617 573 5158  
617 507 2665 fax  
sales@inproxsensors.com

[www.inproxsensors.com](http://www.inproxsensors.com)

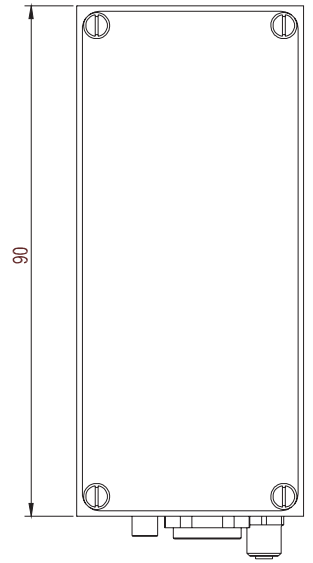
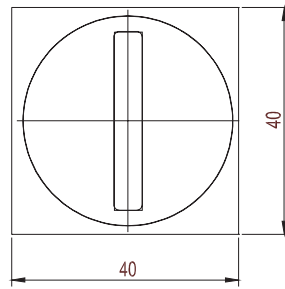
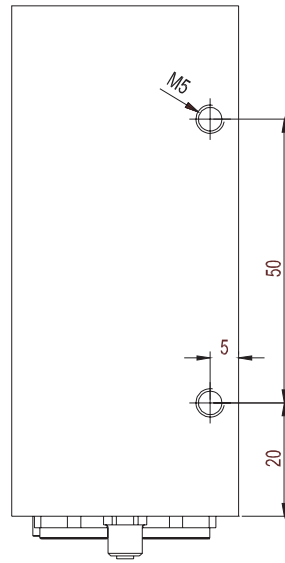
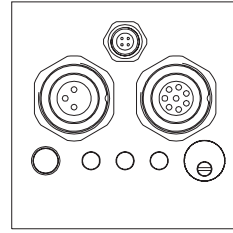
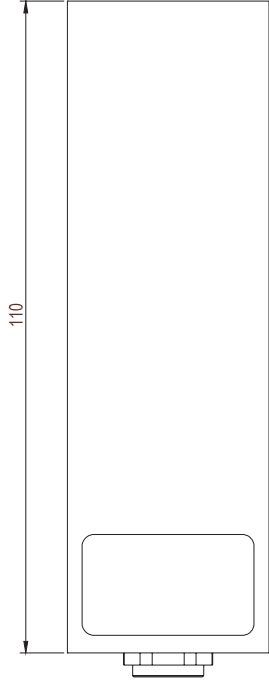
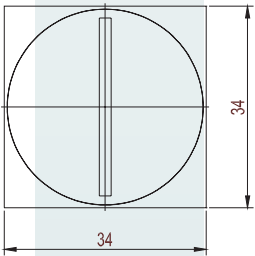
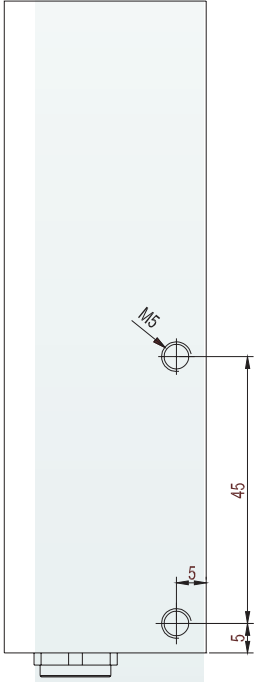
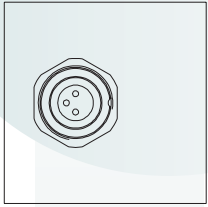

Windows® software TB Scope:

TheMMS25A sensor can be easily parameterised with the Windows® user interface.

For this purpose the sensor is connected to the PC with the serial interface cable cab-las4/PC.

When parameterisation is finished, the PC can be disconnected again.

### Windows® user interface:

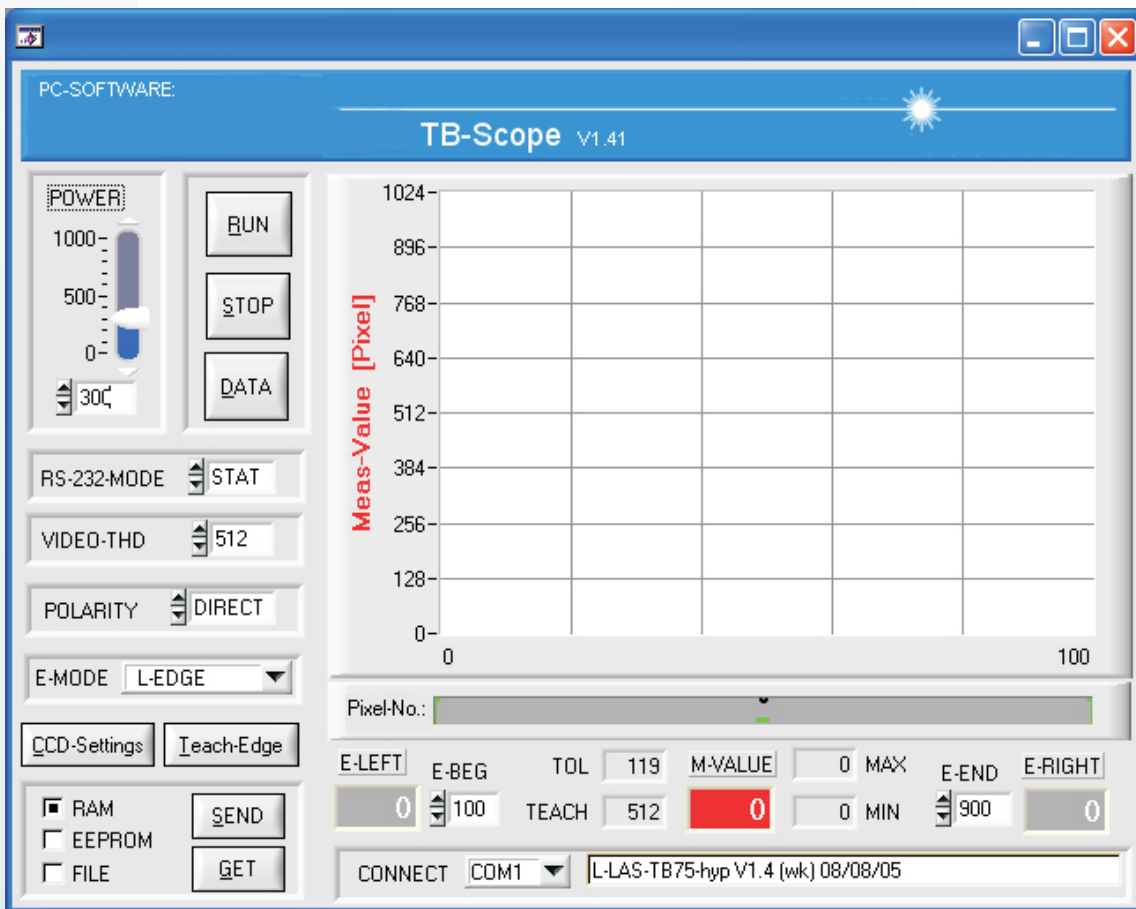

For example, the raw data of the CCD line sensor can be displayed graphically and numerically. In the case of line sensors with 512, 256, or 128 pixels the parameters related to the pixels will be adapted correspondingly!

With the help of the TB-Scope software the following settings can be made at the sensor:

- Setting of laser power and type of automatic power correction
- Polarity of digital outputs
- Different evaluation modes
- Start of the teach process by software button
- Setting of tolerance ranges for monitoring the measured value

Furthermore, various numerical and graphical measured quantities can be visualized with the TB-Scope software.

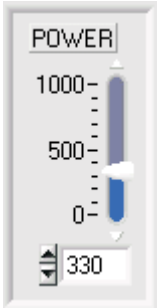

**POWER:**

In this function field the intensity of the laser diode can be set by using the slider or by entering a value in the edit box.

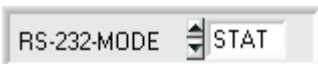

**RS-232 OUTPUT MODE:**

This function field is used for setting the operating mode for the RS232 interface.  
 STAT: The MMS25A sensor does not output measuring data via the serial interface  
 CONT: The MMS25A sensor does continuously output the measuring data via the serial interface (e.g. for the connection to the Windows® Hyperterminal application).

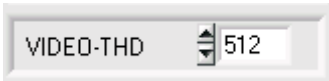

**VIDEO-THD:**

In this function field a numerical threshold can be adjusted. This threshold is used to gain the measured values out of the intensity profile of the CCD line.



**POLARITY:**

The MMS25A sensor has 2 digital outputs (OUT0, OUT1) which can provide the error conditions to the PLC. The POLARITY function field is used for setting the output polarity of the two digital outputs.

DIRECT: In case of an error, the respective digital output switches to +Ub(+12VDC...+32VDC)  
 INVERSE: In case of an error, the reference potential GND (0V) is present at the respective digital output



**E-MODE (Evaluation Mode):**

This drop-down list provides a selection for setting the active evaluation algorithm for the MMS25A sensor.



**Teach-Edge:**

A click on the 'Teach-Edge' button starts the teach process at the MMS25A sensor. In this process the respective set point value of the edges of the measuring object are automatically calculated and stored at the sensor.



**CCD-Settings:**

A click on the 'CCD-Settings' button opens a new graphics window which offers new function elements for the parameterisation of the CCD line.

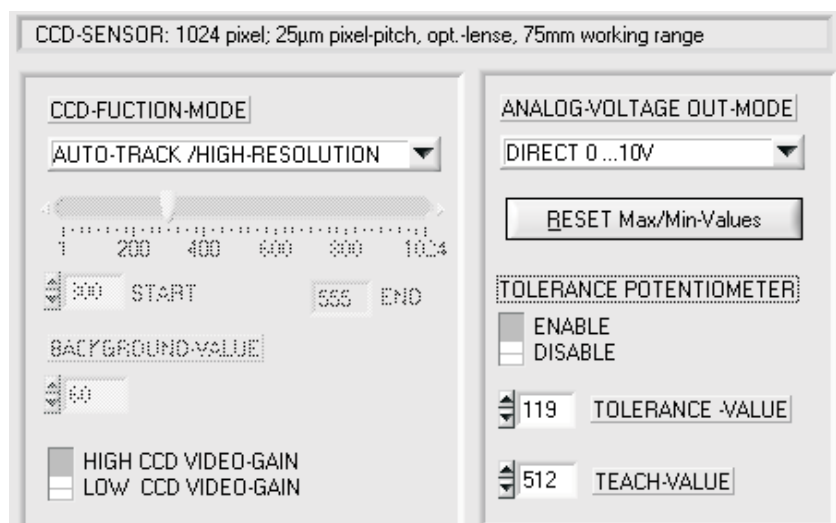

**RUN:**

A click on the RUN button starts continuous measurement data transfer from the MMS25A sensor to the PC through the serial interface; these data are visualised in the numerical and graphical display elements of the TB-Scope.

After a click on the RUN button the graphical output window is updated in the „roll mode“, i.e. the current measurement data (M-VALUE) is shifted from right to left in the graphical output window. Additionally the TEACH VALUE is shown as a black dashed line and the tolerance window is shown by two black thin lines. If one of the MAX/MIN analog output modes is selected, an additional red dashed line displays the current frozen MAX/MIN value.

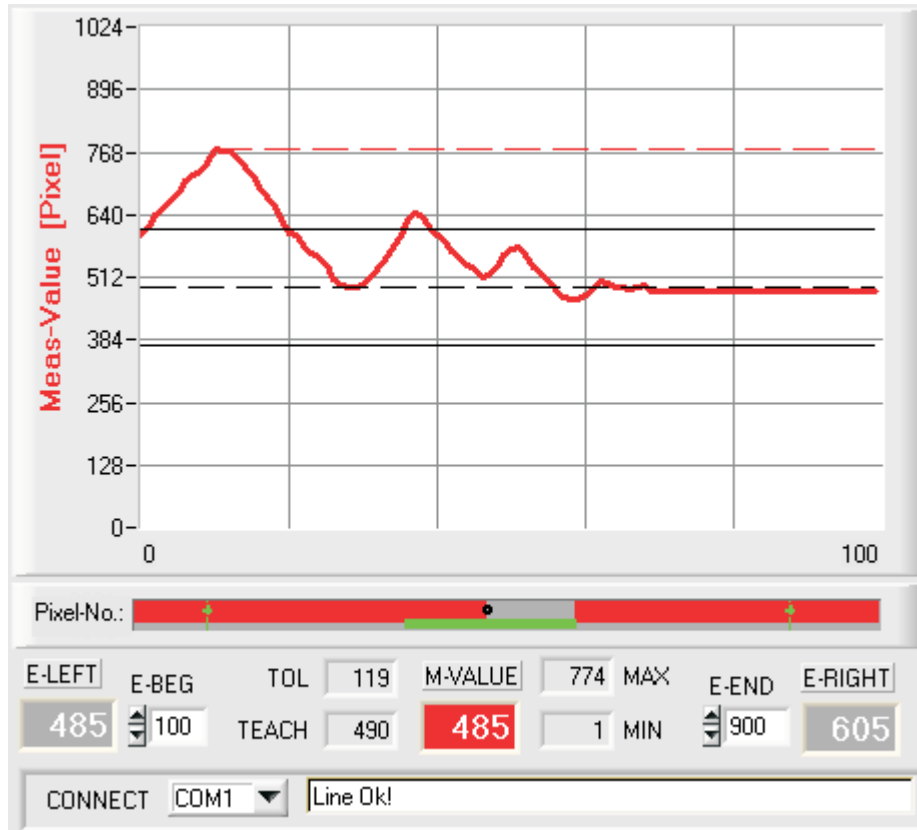
**E-LEFT**

485

**E-LEFT:**

Numerical display element for the left edge of the measuring object.

**M-VALUE**

485

**M-VALUE:**

Numerical display element for the measured value (e.g. diameter of measuring object).

**E-RIGHT**

605

**E-RIGHT:**

Numerical display element for the right edge of the measuring object.

**STOP****STOP:**

A click on the STOP button terminates measurement data transfer from the MMS25A sensor to the PC.