

MTG Series

▶ MTG5F Gloss Detection

- 50 mm reference distance
- Focused laser beam
- Insensitive to outside light (interference filter and modulation)
- Evaluation independent of intensity
- Automatic laser power correction
- Averaging can be activated via PC
- Adjustable polarity of threshold state
- Parameterisable under Windows®
- RS232-interface (USB adaptor available)
- Scratch-resistant optics, sturdy aluminum housing



Design

Product name:

MTG5F

(incl. software G-Scope)

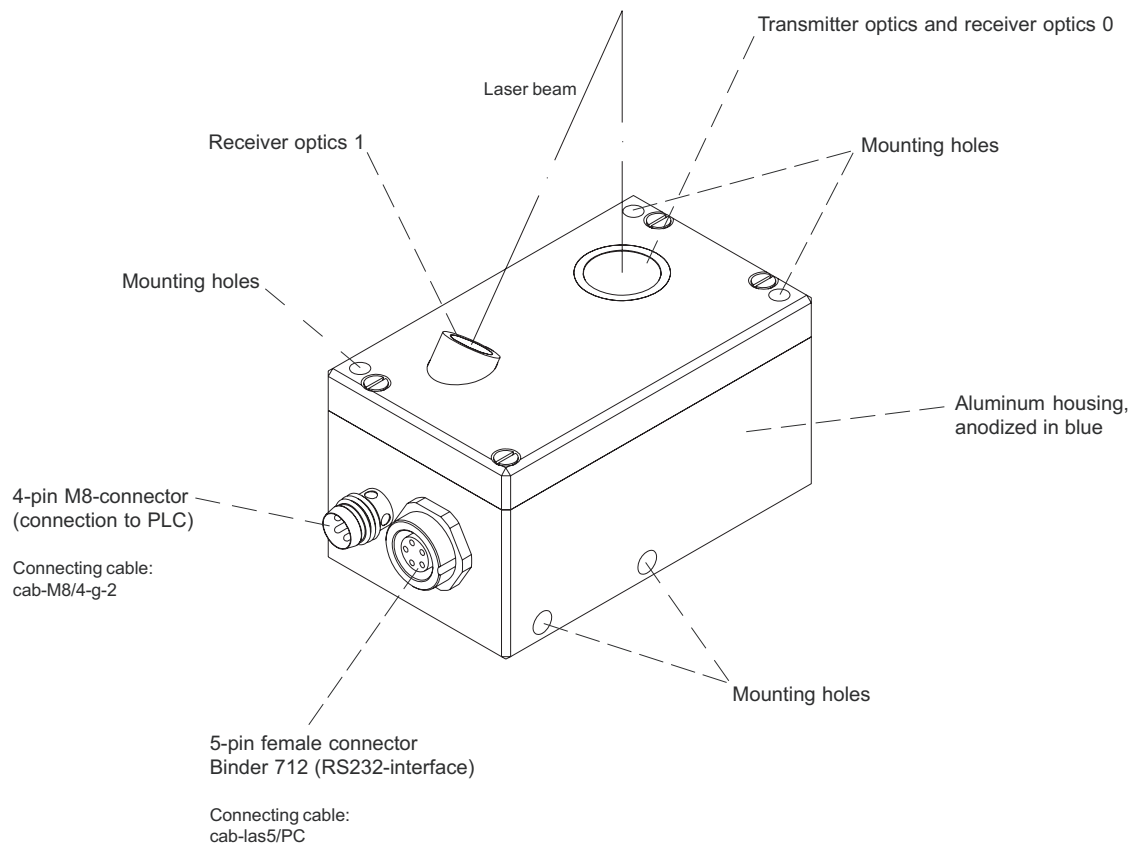



Technical Data

Model	MTG5F
Laser	Solid-state laser, 670 nm, AC-operation, 1 mW max. opt. power, laser class 2 acc. to DIN EN 60825. The use of these laser transmitters therefore requires no additional protective measures.
Reference distance	50 mm
Working range	typ. 40 mm ... 60 mm
Beam geometry	Laser beam focused
Optical filter	Red light filter RG630 + interference filter
Voltage supply	+12VDC ... +32VDC, reverse-polarity protected, overcurrent protected
Operation	100 kHz
Ambient light	up to 5000 Lux
Enclosure rating	IP67
Current consumption	approx. 110 mA
Interface	RS232, parameterisable under Windows®
EMC test acc. to	IEC - 801... 
Type of connector	Connection to PLC: 4-pin M8-connector, connection to PC: 5-pin female connector Binder Series 712
Operating temperature range	-20°C ... +55°C
Storage temperature range	-20°C ... +85°C
Housing	Aluminum, anodized in blue
Pulse lengthening	0 ms, 25 ms, 50 ms, 100 ms, 200 ms (parameterisable under Windows®)
Max. switching current	100 mA, short-circuit protected
Switching frequency	typ. 3 kHz (depends on parameter setting)
Outputs	1x tolerance output (window) 1x switching threshold (reference)
Bright-/dark-switching	parameterisable under Windows®
Laser power adjustment	parameterisable under Windows®
Switching hysteresis	parameterisable under Windows®
Switching state indication	by means of an orange LED integrated in the M8-connector
Averaging	from 1 to 64 values (adjustable under Windows®)



Dimensions

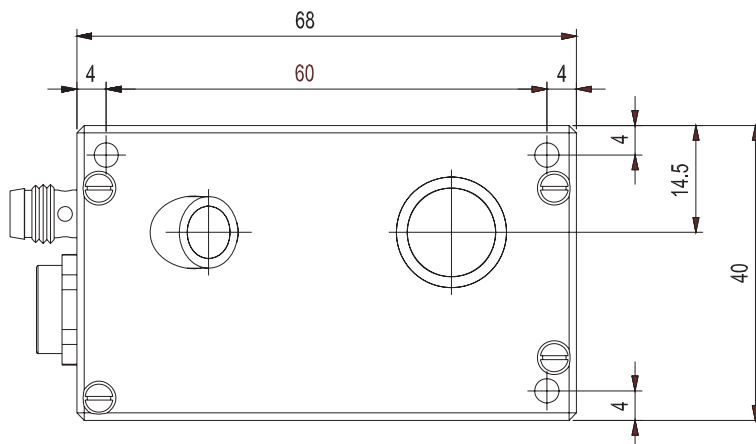
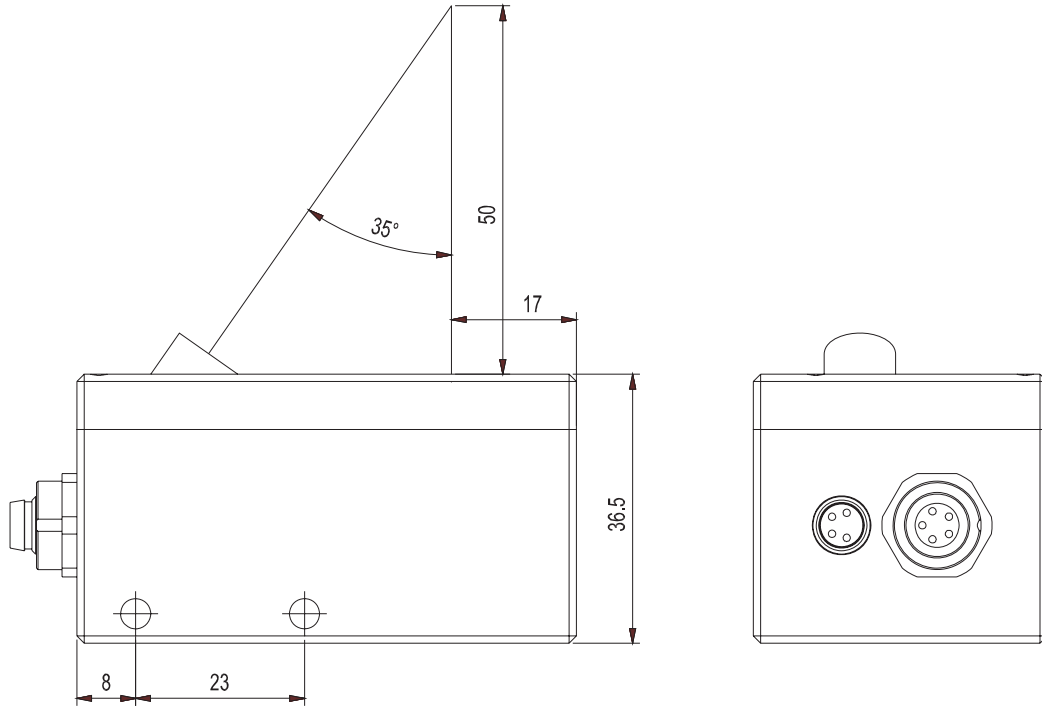

(All dimensions in mm)

Connector Assignment

Connection to PLC:

4-pole connector M8

Pin No.:	(Color)	Assignment:
1	(brn)	+12VDC...+32VDC
2	(wht)	TOLOUT (100mA)
3	(blu)	0V (GND)
4	(blk)	REFOUT (100mA)

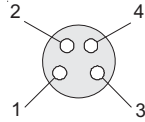

Connection to PC:

5-pole female connector Binder 712

Pin:	Assignment:
1	GND (0V)
2	TX0
3	RX0
4	n.c.
5	n.c.

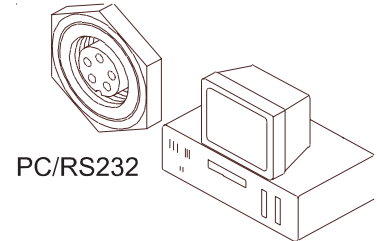
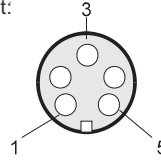



Connecting Cables

Connecting cables:

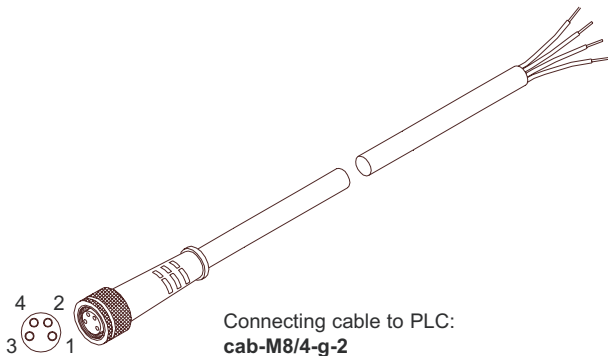
cab-M8/4-g-2 Length: 2m Outer jacket: PUR
cab-las5/PC Length: 2m Outer jacket: PUR

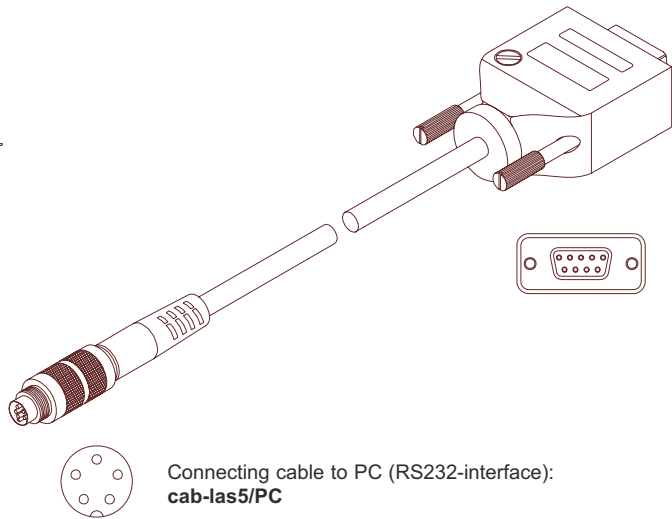

Connecting cable to PLC:
cab-M8/4-g-2



Connecting cable to PC (RS232-interface):
cab-las5/PC

Laser Warning

The laser reflex sensors of MT Series comply with laser class II according to EN 60825. The use of these laser sensors therefore requires no additional protective measure.

The laser reflex sensors of MT Series are supplied with a laser warning label.

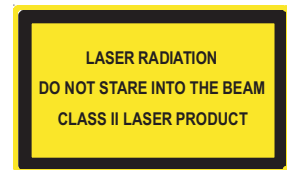

Setting Hints

Design:

The sensor is placed in an angle which is dependent on the distance from the sensor to the object (ideal 50 mm) in a way that the angle of incidence at the object is equal to the angle of reflection and impinges at receiver 1.

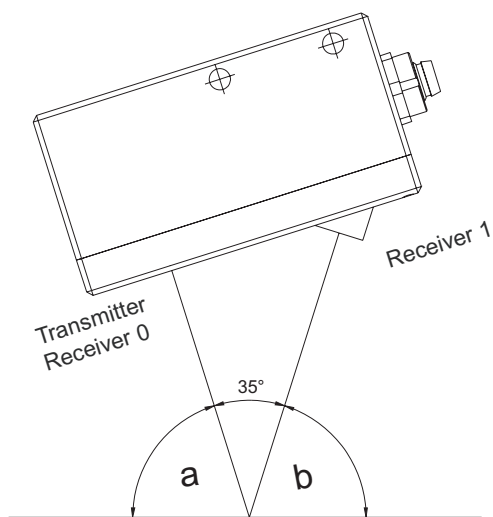
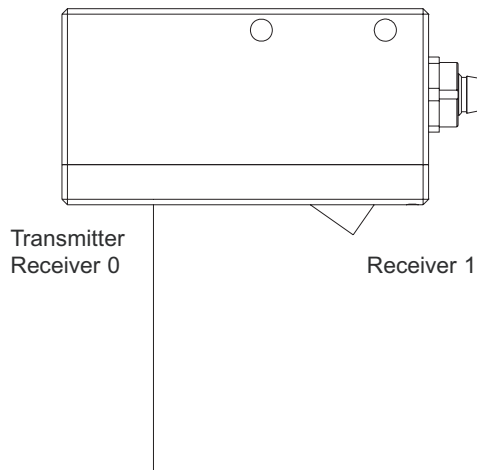

$$a = b$$

Parameterization

Parameterization under Windows® with software G Scope:

With the MTG5F parameter input is performed under Windows® through the serial RS232 interface. All the parameters are stored in the EEPROM of the MTG5F.

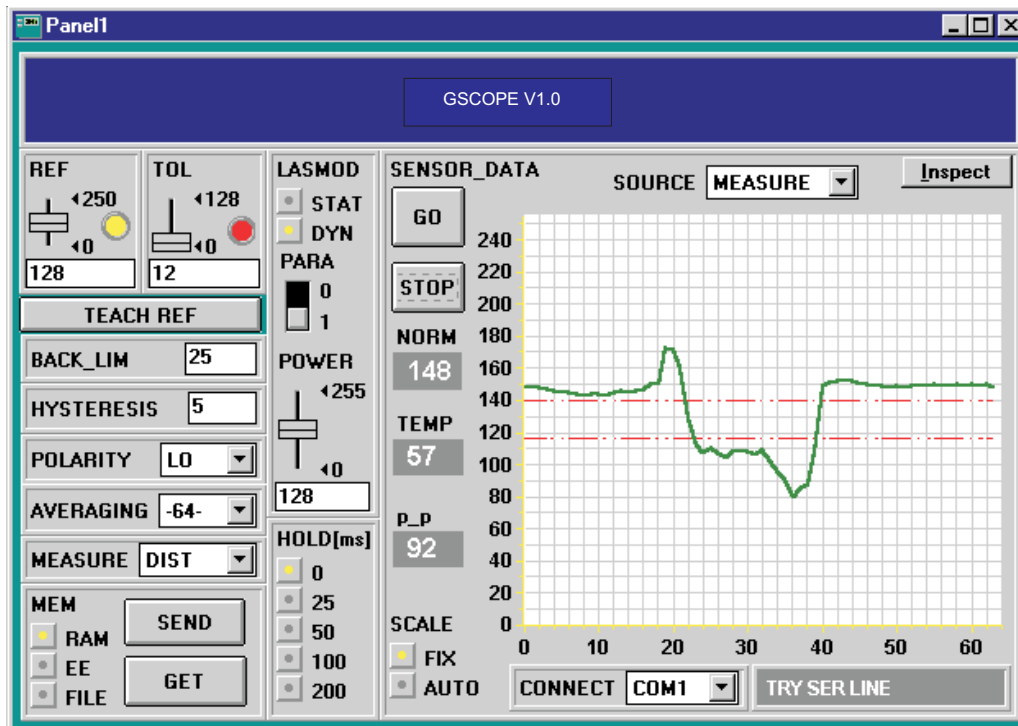

Parameter setting

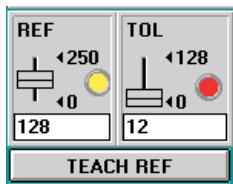

Tolerance, Reference (TOL, REF):
Software sliders for reference and tolerance value. By clicking on the TEACH REF field the current distance value (standardized value) is stored as the new reference value in the non-volatile memory of the laser sensor.

The permissible deviation (+/-) of the standardized value (distance value) from the reference value can be adjusted with a mouse-click on a software slider. The switching state changes at pin 2 of the 4-pin M8-plug (TOLOUT), when the value leaves the tolerance band.

The reference value can be adjusted with another software slider. If the current distance value exceeds or falls below the reference value, the switching state at pin 4 of the 4-pin M8-plug changes (REFOUT).

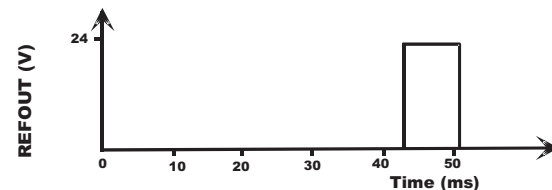
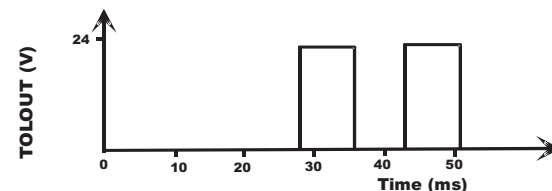
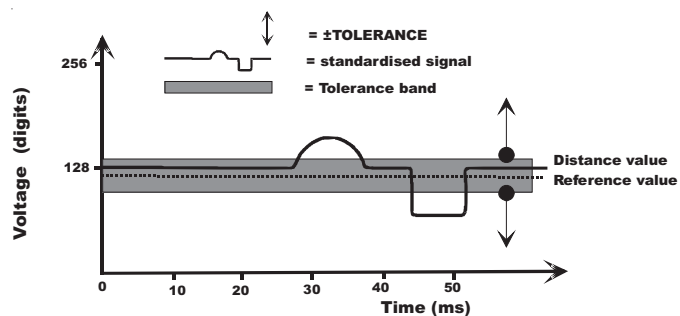
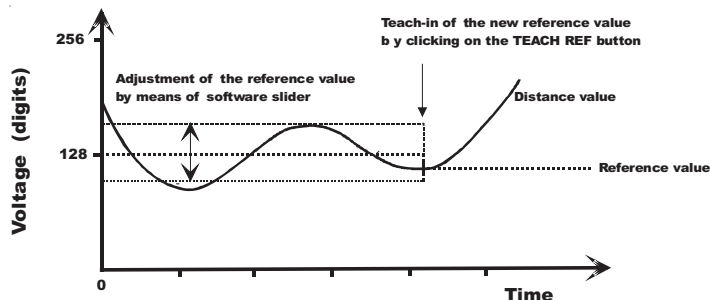

Parameterization

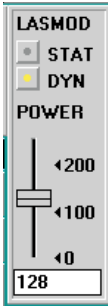

Laser power, laser power correction (LASMOD, POWER):

The laser power can also be adjusted by means of a software slider.

It must be noted that the laser power can only be changed, if the software switch for automatic laser power correction LASMOD is set to STAT. Furthermore automatic laser power correction can be switched ON (DYN) or OFF (STAT) under Windows® with a mouse-click in the software field LASMOD. If automatic laser power correction is active, the laser sensor tries to bring the two input signals („RAW data“) to the value of 256.

It must be noted that INTENSITY mode automatic laser power correction must be switched to STAT in the MEASURE field.

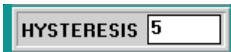

Switching hysteresis (HYSTERESIS):

it may be possible that different applications require an adjustable switching hysteresis. For this purpose a software field is provided for switching hysteresis adjustment.

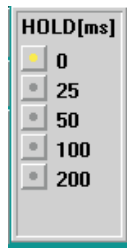

Pulse lengthening, bright-/dark-switching (HOLD, POLARITY):

With a minimum scan time of 150 µs most SPCs have problems with the detection of the relatively short switching pulse.

With the laser sensors of R-LAS-LT series pulse lengthening can be activated under Windows® by means of a software switch in the HOLD (ms) field. Pulse lengthening can be selected between 0ms and 200ms.



The POLARITY software switch is used for switching over between bright- and dark-switching.

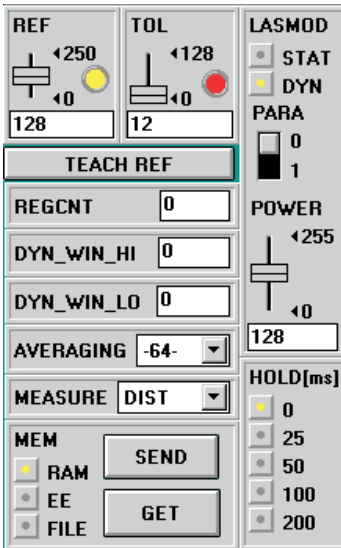

Parameter display (PARA):

A click on the PARA software switch either displays the „BACK_LIM“, „HYSTERESIS“, and „POLARITY“ parameters, or „REGCNT“, „DYN_WIN_HI“, and „DYN_WIN_LO“. The last three parameters also are referred to as a control block.



Time constant with activated automatic laser power correction (DYN-Mode):

In accordance with the entered value n (n = 1 ... 255) the laser power is automatically corrected at every n-th scan (measured value interrogation), i.e. with n = 1 the control time constant is low, with n = 255 it is high!



Upper limit of the setpoint range (maximum permissible intensity):

The control algorithm (DYN mode) tries to keep the laser power (intensity) that is measured by the laser sensor within a setpoint range. The setpoint range limits can be set with the software.

DYN_WIN_HI forms the upper setpoint limit, i.e. if the measured intensity lies above the upper setpoint limit, the laser power will be reduced.



Lower limit of the setpoint range (minimum permissible intensity):

DYN_WIN_LO forms the lower setpoint limit, i.e. if the measured intensity (signal1+signal2)/2 lies under the lower setpoint limit, the laser power will be increased.

Parameterization

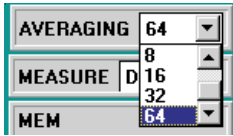

Averaging (AVERAGING):

In the AVERAGING field a selection can be made from several steps. The activated figure defines the number of values that should be averaged. The maximum number of values to be averaged is 64, i.e. an accuracy increase by the factor 8 can be achieved.



Measuring mode (MEASURE):

With a mouse-click a selection can be made between DIST mode and INTENSITY mode. In DIST mode the two input signals (RAW data) are standardized according to the following algorithm: $(U1-U2)/(U1+U2)$; U1, U2 = input signals. In DIST mode distance checking is performed independently of the intensity, whereas in INTENSITY mode the mean value of the two input signals is of interest: $(U1+U2)/2$. This means that evaluation is performed depending on the intensity (contrast evaluation).



Background suppression (BACK_LIM):

The laser sensors of MTG-T-LS series operate according to the triangulation principle. Evaluation is performed by way of an algorithm that is independent of the intensity. This standardized value provides information about the distance.

Additional background suppression is performed by way of additional monitoring of the mean value of the two input signals U1 and U2: $(U1+U2)/2$.

If this mean value falls below the preset BACK_LIM value, the calculated standardized value $(U1-U2)/(U1+U2)$ is replaced by the value 256, i.e. in case of very low signal levels (mostly caused by the background) "biasing" to an infinitely large distance (corresponds with 256) is performed instead of the insecure distance information.

Graphical representation:

Adjustment of the laser sensors of MTG-T-LS series is considerably supported by means of graphical representation of the two receiver signals or the standard signal (with T version) on the PC under Windows®.

Starting graphical representation (GO/STOP):

Graphical representation under Windows® is started by clicking on the GO field. Clicking on the STOP field stops the graphical representation on the PC monitor.

Graphical representation (SOURCE):

In the SOURCE field a selection can be made with a mouse-click between the two receiver signals RAW and the calculated MEASURE signal (depending on MEASURE mode INTENSITY or DIST).

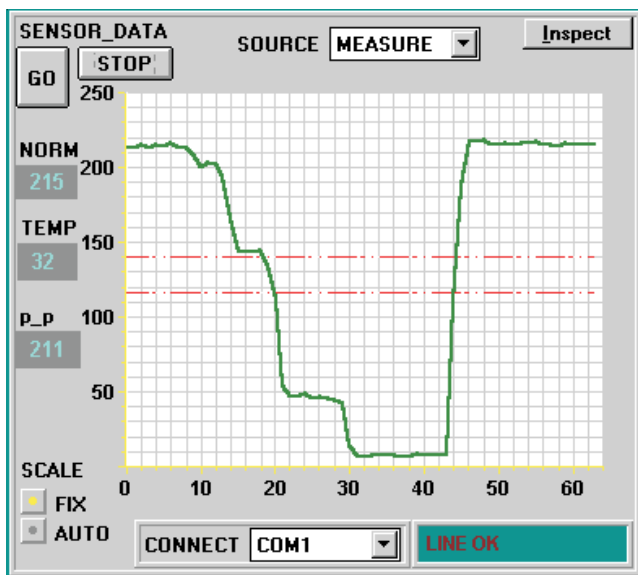

Graphical representation of the calculated MEASURE signal

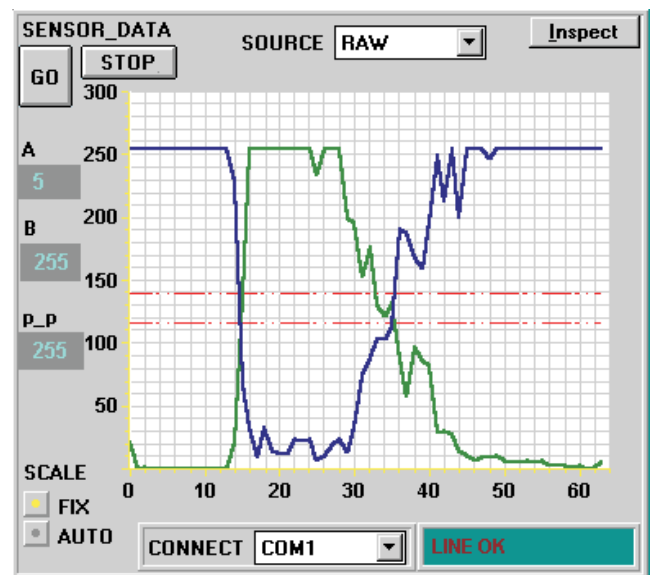

Graphical representation of the calculated RAW signals

Parameterization
Interface selection (CONNECT):

In the CONNECT software field the serial interface that is used can be selected (COM1 to COM4). The LINE OK or TIME OUT message provides information on the success or failure of connection setup between laser sensor and PC.

Display mode (SCALE):

In the SCALE software field a selection can be made between FIX, i.e. display over 256 digits (complete 8 bit range) and AUTO, which only displays the area that is of interest with respect to the signal.

Parameter readout (MEM) from the laser sensor or file:

After a mouse-click on the GET "software button" the parameters can be read out from the RAM or EEPROM of the laser sensor or from a file on the harddisk or on a floppy disk, depending on the switch position.

Print mode (Inspect):

Clicking on the INSPECT field starts a printout of the signals displayed on the monitor.

Numerical display::

The values read in last are displayed numerically. In case of SOURCE MEASURE the determined DIST or INTENSITY value, a relative temperature value, and the peak-to-peak value of the represented DIST or INTENSITY value is displayed. In SOURCE mode RAW the current input signals A and B or the peak-to-peak value of the A signal are displayed.

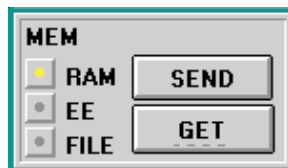
**Parameter storing (MEM) in the laser sensor or in a file:**

With the SEND software button the parameters entered with software sliders or software switches can be transferred to the RAM or EEPROM of the laser sensor. If the FILE switch is activated, the parameters can be stored in a freely selectable file on floppy disk or hard disk.

If the data are stored in the RAM they will be lost when the laser sensor is switched off!

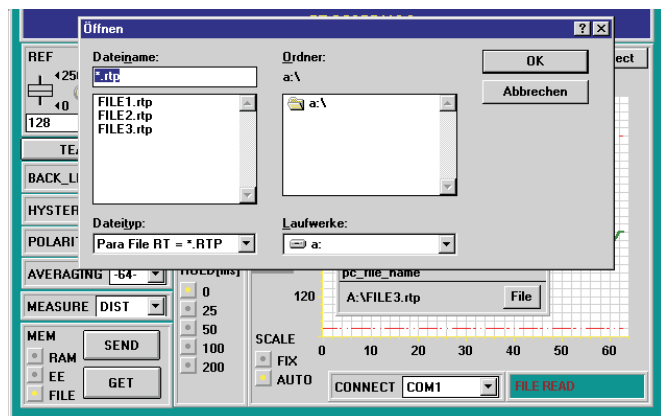

When the FILE switch in the MEM field is activated a pc_file_name field will appear in the graphic windows which provides information about the file currently selected. Another file can be selected or created by clicking on FILE on the pc_file_name field.

Working with the laser sensors of MTG-T-LS series:

After parameter input and sensor adjustment with the help of graphical representation on the PC display the PC is no longer necessary for the actual measuring task. The PC with the interface cable can then be disconnected from the sensor.