

M30 100m (325') Ultra Harsh Duty Self Contained Photo-Electric Transmitter

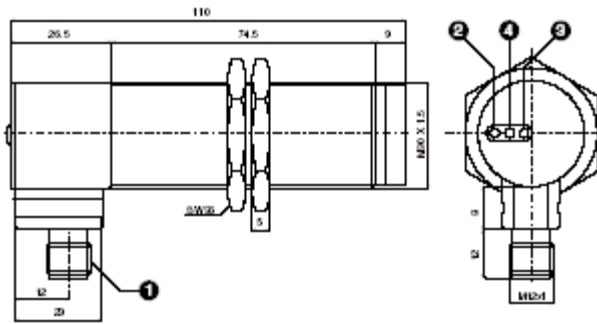

**M30 100m (325') Range
Harsh Duty Self Contained**

Ultra Harsh Photo Electric Sensor

Car Wash, Industrial, Long Distance

4 wire 10-30VDC

3 LED's for set up & diagnostics

Integrated Check Function

M12 right angle connector

IP67 protection degree

Protection from electrical damages

Metal housing-NBT

- 1** K3 M12 4 pin connector
- 2** Green LED (supply)
- 3** Yellow LED (check transmitter emission)
- 4** Red LED (alignment)

Parts Matrix

photo electric sensor series	P
transmitter (check)	TCH
100 meter range (325')	100
M30 30mm body diameter	9
metal housing-NBT	B
straight optics	T
M12 4 Pin 12mm connector	K3
range (mm)	100m

Part Number Specifications

PTCH1009BTK3 TRANSMITTER K3

Wiring Diagram

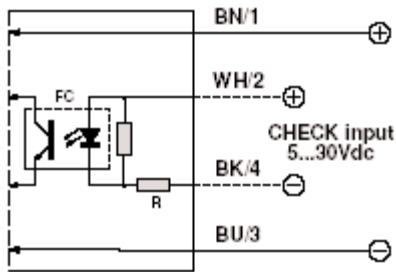

Connector Diagram

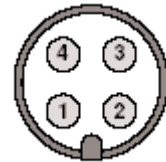

TECHNICAL SPECIFICATIONS

Nominal Sensing Distance S_n	100m (325')
Emission	infrared (880nm)
Differential Travel	10%
Repeat Accuracy R	2%
Operating Voltage U_b	10-30VDC
Ripple U_{pp}	<10% U_b
Check Threshold	ON=2.5V OFF=1.5V
Check Voltage	5-30VDC
Check Current	3.5mA
No-load Supply	50mA
Load Current I_a	-
Leakage Current	-
Voltage Drop U_d	-
Output Type	-
Response Time	ON state=500us OFF state=400us
Time Delay Before Availability t_v	100ms
Supply Electrical Protections	polarity reversal, transient
Output Electrical Protections	-
Ambient Temperature T_a	-25--+70C
Temperature Drift	+/- 10% SR
Protection Degree (DIN 40 050)	IEC IP67
LED Indicators	green, yellow, red,
Housing Material	nickel plated brass
Lenses Material	PMMA
Tightening Torque	100Nm
Weight (approximate)	250g